

SPECIFICATION FOR APPROVAL

Description : Piezo Audio Indicator
Part No. : 2260(RoHS)
Customer's Model No. : _____
Specification No. : _____
: _____

CUSTOMER'S APPROVED SIGNATURE		

Approved by	Checked by	Issued by
		Feng 11/25/08'



A.SCOPE 範疇

2260(RoHS)

This specification applies piezo audio transducer,

B. SPECIFICATION 規格

No.	Item	Unit	Specification	Condition
1	Operating Frequency 操作頻率	KHz	3.5±0.5	
2	Operating Volt. range 操作電壓範圍	VDC	3~28	
3	Operating Current 操作電流	mA	MAX 4	at 12VDC
4	Sound pressure level 輸出音壓	dB	MIN 85	at 30 cm/12VDC
5	Rated Voltage 額定電壓	VDC	12	
6	Tone 聲音		Continuous 直音	at 12VDC
7	Operating temp 操作溫度	°C	-30~+85	
8	Storage temp. 儲存溫度	°C	-40~+95	
9	Dimension 尺寸	mm	φ32.0XH13.5	See appearance drawing 請參照外觀尺寸圖
10	Weight (MAX) 重量	gram	8.0	
11	Material 材質		ABS UL-94 1/16" HB HIGH HEAT (BLACK)	
12	Terminal 端子		Wire type	See appearance drawing 請參照外觀尺寸圖
13	Environmental Protection Regulation 環保法規		RoHS	

C. APPEARANCE DRAWING 外觀尺寸圖

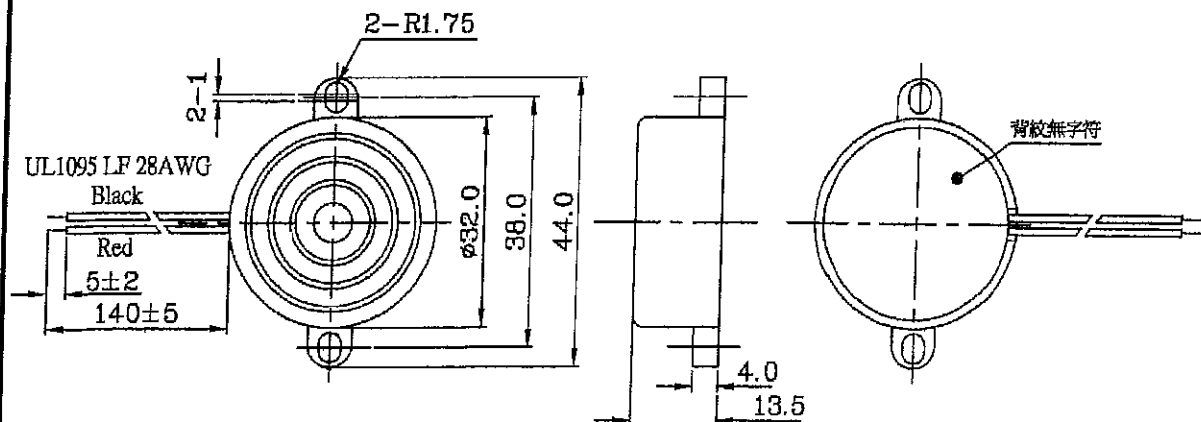

Tol : ± 0.5

Unit : mm



D. MEASURING METHOD 測量方法

2260(RoHS)

S.P.L. Measuring Circuit 音壓測試接線圖

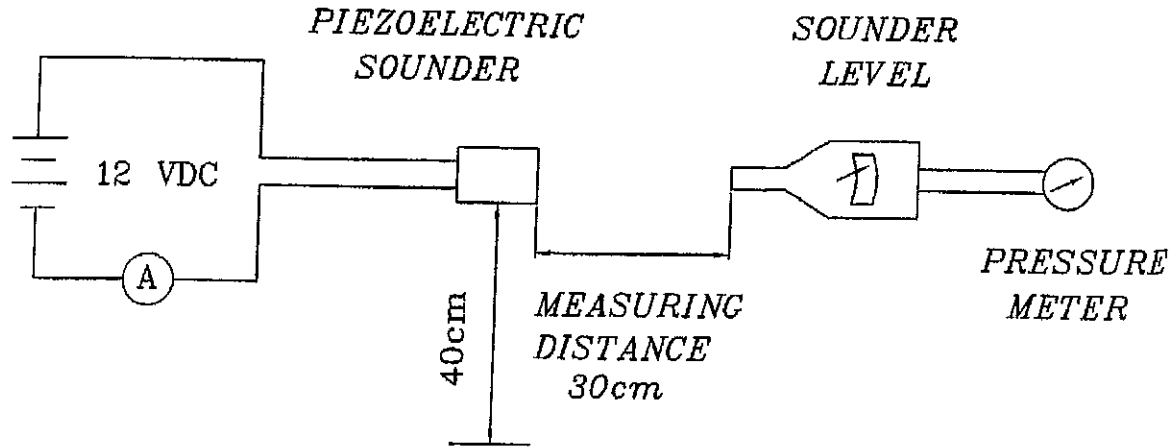

Mic : RION S.P.L meter UC30 or equivalent

Mic : RION 噪音計 UC30 或同等品

S.G : Hewlett Packard 33120A Function Generator or equivalent

S.G : Hewlett Packard 33120A 函數信號產生器 或同等品

E. VOLTAGE: SOUND PRESSURE LEVEL VOLTAGE: CURRENT CONSUMPTION

CHARACTERISTICS 電壓與音壓 電壓與耗電流之特性

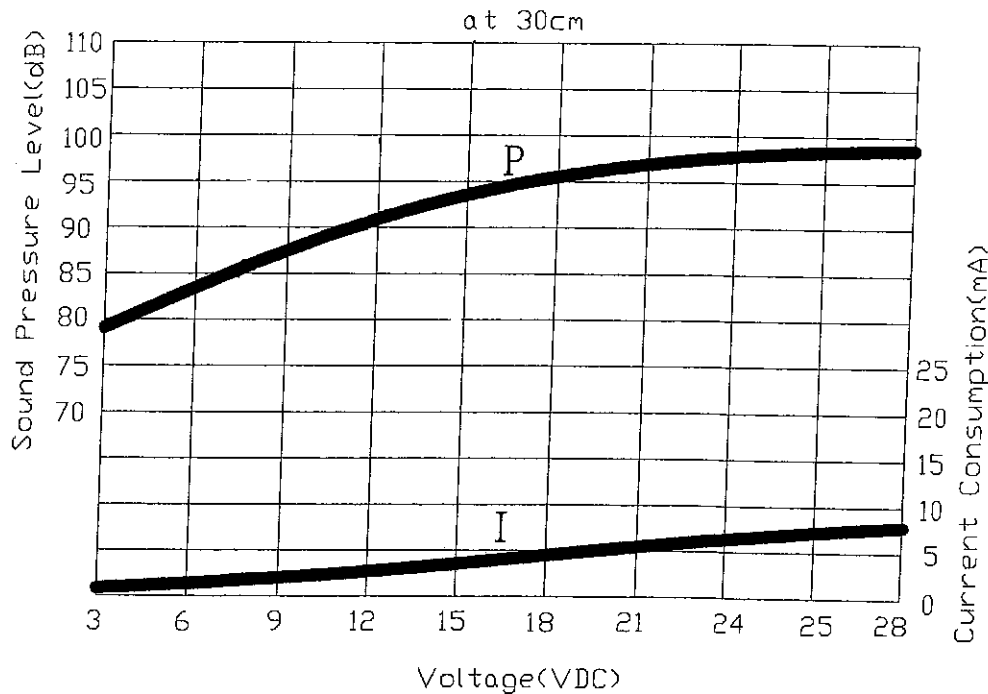

F. MECHANICAL CHARACTERISTICS 機械特性

2260(RoHS)

No.	Item	Test Condition	Evaluation standard
1	Solderability 焊錫附着性 (Connector excepted) (端子類不適用此項)	Stripped wires of lead wires are immersed in rosin for 5 seconds and then immersed in solder bath of +270±5°C for 3±0.5 seconds. 裸線部份浸入松香溶液 5 秒後,再浸入+270±5°C 熔融焊錫槽 3±0.5 秒。	90% min. stripped wires shall be wet with solder.(Except the edge of terminal) 浸入裸線部份附着焊錫 90% 以上。(末端斷面不算)
2	Lead Wire Pull Strength 線材拉力	The pull force shall be applied to double lead wire : Horizontal 3.0N(0.306kg) for 30 seconds. Vertical 2.0N(0.204kg) for 30 seconds. 雙線材水平方向施以 3.0N(0.306kg) 的力量, 垂直方向施以 2.0N(0.204kg) 的力量,各 30 秒。	No damage and cutting off. 線材不鬆動,不脫落。
3	Vibration 振動試驗	Buzzer shall be measured after being applied vibration of amplitude of 1.5mm with 10 to 55hz band of vibration frequency to each of 3 per-pendicular directions for 2 hours. 振動週波數 10~55HZ、全振幅 1.5mm 於 X,Y,Z 3 個方向,各 2 小時。	The value of oscillation frequency/ current consumption should be in ±10% compared with initial ones .The SPL should be in ±10dB compared with initial one.
4	Drop test 落下測試	The part only shall be dropped from a height of 75cm onto a 40mm thick wooden board 3 times in 3 axes (X,Y,Z), (a total of 9 times). 單體從 75 公分高處, X,Y,Z 3 個方向,各 3 回,落於 40mm 厚木板。	諧振頻率與消耗電流變化量須在 ±10% 內。輸出音壓變化量須在 ±10dB 內。

G. ENVIRONMENT TEST 環境測試

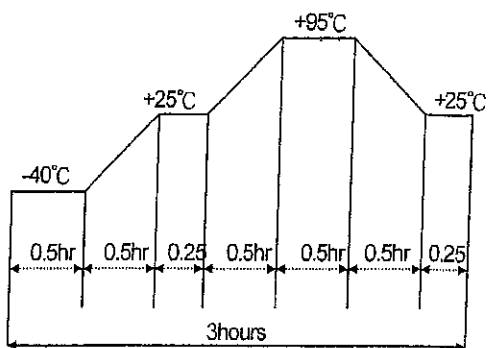
No	Item	Test Condition	Evaluation standard
1	High temp. test 高溫測試	After being placed in a chamber at +95°C for 240 hours 置於+95°C 環境中 240 小時	Being placed for 4 hours at +25°C, buzzer shall be measured. The value of oscillation frequency/ current consumption should be in ±10% compared with initial ones .The SPL should be in ±10dB compared with initial one. 經測試後, 靜置於+25°C (室溫) 環境中 4 小時後, 諧振頻率與消耗電流變化量須在 ±10% 內。輸出音壓變化量須在 ±10dB 內。
2	Low temp. test 低溫測試	After being placed in a chamber with - 40°C for 240 hours 置於-40°C 環境中 240 小時	
3	Humidity test 相對濕度測試	After being placed in a chamber at +40°C and 90±5% relative humidity for 240 hours 置於+40°C, 相對濕度 90±5% 環境中 240 小時	
4	Temp. cycle test 溫度循環試驗	The part shall be subjected to 5 cycles. One cycle shall be consist of : : 單體承受溫度及循環測試 5 次,其循環內容如圖示: 	



No.	Item	Test condition	Evaluation standard
1	Operating life test 壽命測試	1. Continuous life test 高溫壽命測試(連續) 48 hours continuous operation at +70°C with rated voltage applied. 在+70°C境下,以額定電壓連續操作48小時。 2. Intermittent life test 室溫壽命測試(間歇) A duty cycle of 1 minute on, 1 minutes off, a minimum of 5000 times at room temp. (+25±2°C) and rated voltage applied 在室溫下(+25±2°C),以額定電壓操作,通電1分鐘/斷電1分鐘,測試5000次循環。	Being placed for 4 hours at +25°C, buzzer shall be measured. The value of oscillation frequency/ current consumption should be in±10% compared with initial ones. The SPL should be in±10dB compared with initial one. 經測試後,靜置於+25°C(室溫)環境中4小時後,諧振頻率與消耗電流變化量須在±10%內。輸出音壓變化量須在±10dB內。

TEST CONDITION.

Standard Test Condition 一般測試條件	:	a) Temperature : +5 ~ +35°C	b) Humidity : 45-85%	c) Pressure : 860-1060mpa
Judgement Test Condition 爭議時測試條件	:	a) 溫度 : +5 ~ +35°C	b) 濕度 : 45-85%	c) 氣壓 : 860-1060mpa
	:	a) Temperature : +25 ± 2°C	b) Humidity : 60-70%	c) Pressure : 860-1060mpa
	:	a) 溫度 : +25 ± 2°C	b) 濕度 : 60-70%	c) 氣壓 : 860-1060mpa

I. PACKING STANDARD 包裝規格

