

SPECIFICATION FOR APPROVAL

Product	PIEZO BUZZER (SELF DRIVE)
Part No.	2272A (RoHS)
Customer Approval	

Approved By	Checked By	Made By
ERIC WANG JUN-21-2006	DAVID LIU JUN-21-2006	JOHN HSU JUN-21-2006



SHOGYO INTERNATIONAL CORP.
6851 JERICHO TURNPIKE, SYOSSET, N.Y. 11791
TEL: (516) 921-9111 • FAX: (516) 921-3777
www.shogyo.com

1. Specifications

2272A(RoHS)

Items		Units	Specifications	Conditions
01	Rated Voltage	VDC	12	
02	Operating Voltage	VDC	3 ~ 20	
03	Rated Current	mA(Max)	10	At 12VDC
04	Sound Output At 30cm	dBA(Min)	93	At 12VDC
05	Resonant Frequency	Hz	3500±500	
06	Tone Nature	CONTINUEOUS		
07	Operating Temp.	°C	-20 ~ +60	
08	Storage Temp.	°C	-20 ~ +70	
09	Weight	g	7.5	

2. Measuring Method

2-1. Test Condition

STANDARD

Temperature : 15 ~ 35°C

Relative humidity : 25% ~ 85%,

Atmospheric pressure : 860mbar to 1060mbar.

JUDGEMENT

Temperature : 20±3°C

Relative humidity : 60% ~ 70%,

Atmospheric pressure : 860mbar to 1060mbar



SHOGYO INTERNATIONAL CORP.
6851 JERICHO TURNPIKE, SYOSSET, N.Y. 11791
TEL: (516) 921-9111 • FAX: (516) 921-3777
www.shogyo.com

2-2. Standard Test Fixture

2272A (RoHS)

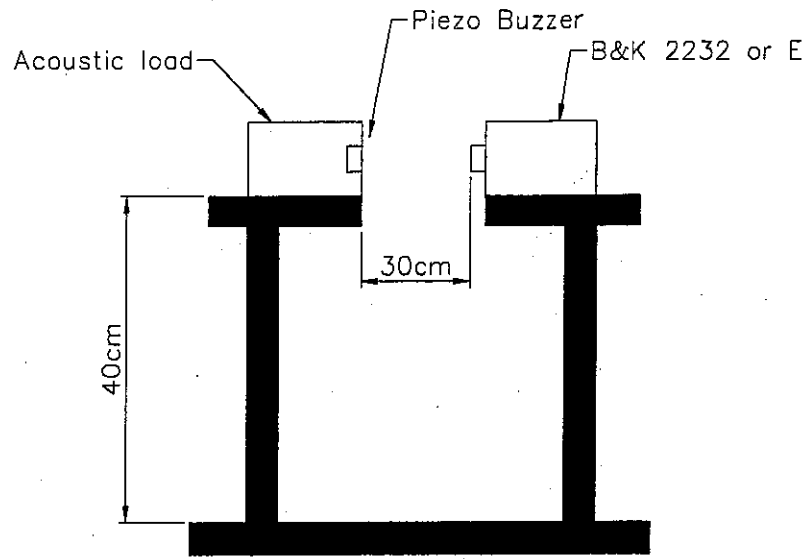

2-3. Characteristic Curve

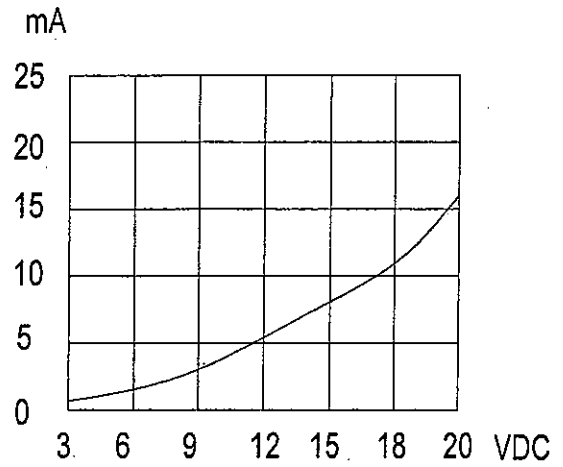
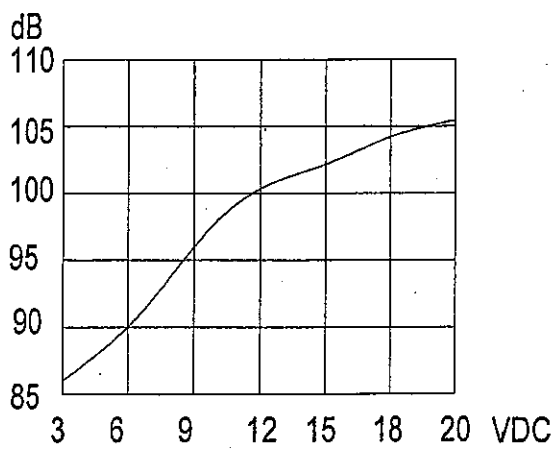

SHOGYO INTERNATIONAL CORP.
6851 JERICHO TURNPIKE, SYOSSET, N.Y. 11791
TEL: (516) 921-9111 • FAX: (516) 921-3777
www.shogyo.com

4. Reliability Test

2272A (RoHS)

	Item	Conditions	Evaluation standard
01	Low Temp. Storage Test	-40°C±2°C ,240Hr	After the test the part shall meet specifications without Any degradation and performance except S.P.L S.P.L shall be 74dB or more.
02	High Temp.Storage Test	85°C±2°C ,240Hr	
03	Temp./Humidity Storage Test	40°C±2°C , RH90-95% 240Hr	
04	Thermal Shock Test	-40°C±2°C (0.5Hr)→ ,20°C±2°C (0.25Hr) 85°C±2°C (0.5Hr)→ ,20°C±2°C (0.5Hr) 5 cycles	
05	Vibration Test	10-55Hz/2 Hr amplitude 1.5mm X,Y, Z,3 directions	
06	Mechanical Shock Test	+100G,Half Sine wave, XYZ , 3 impacts per axis ,3 times.	
07	Free Drop Test	The part shall be dropped freely from a height of 75 cm X,Y, Z,3 directions 3times (total 9 times)	
08	Life Burning Test	The part shall be subjected to 500 hrs in the room temp with rated voltage applied	
09	Lead Strength Test	Pull Lead with a force of 10N,on the direction of the lead axis for 10±1 sec.	



SHOGYO INTERNATIONAL CORP.
 6851 JERICHO TURNPIKE, SYOSSET, N.Y. 11791
 TEL: (516) 921-9111 • FAX: (516) 921-3777
www.shogyo.com

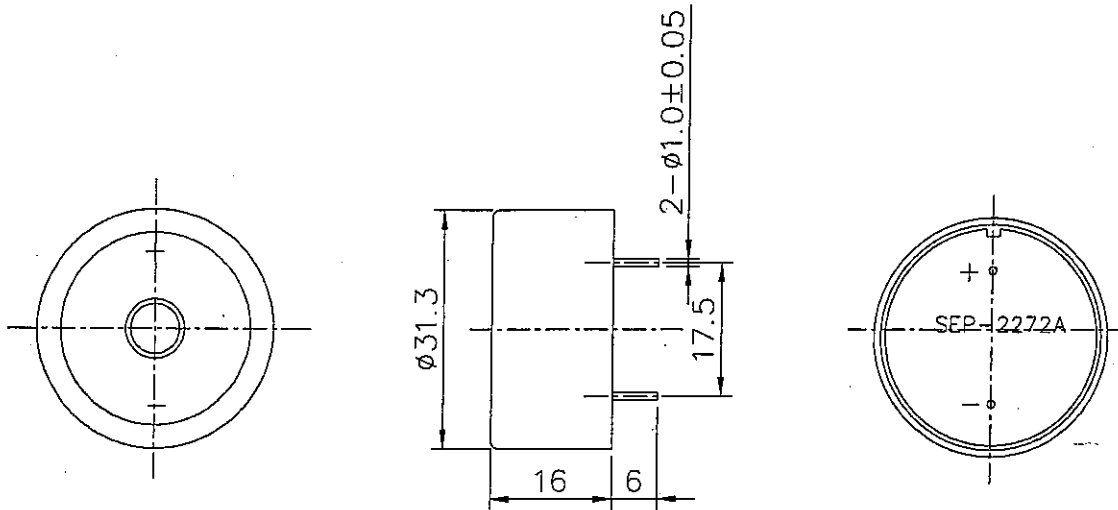

RoHS

TITLE: PIEZO BUZZER		DRAWN: <i>Killy</i> 2005/02/19	SCALE: 1:1	SHEET: 1 of 1
PART NO. 2272A (RoHS)	1	DESIGNED: R & D	UNITS: mm	
DWG NO. DPE-1115		CHECKED:	TOLERANCE ± 0.5	
	REV	APPROVAL:	UNLESS OTHERWISE SPECIFIED:	
		MATERIAL: ABS	ONE PLACE DECIMAL ± ***	
			TWO PLACE DECIMAL ± ***	
			THREE PLACE DECIMAL ± ***	

