

REV	DESCRIPTION	DATE
1	Black Conduct	2007.01.27

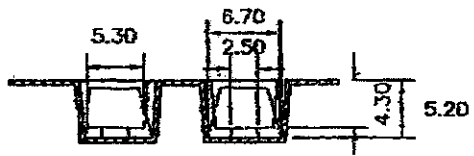
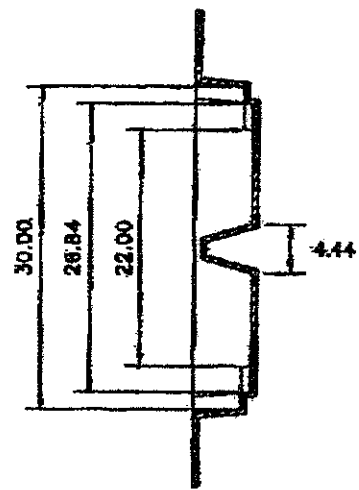
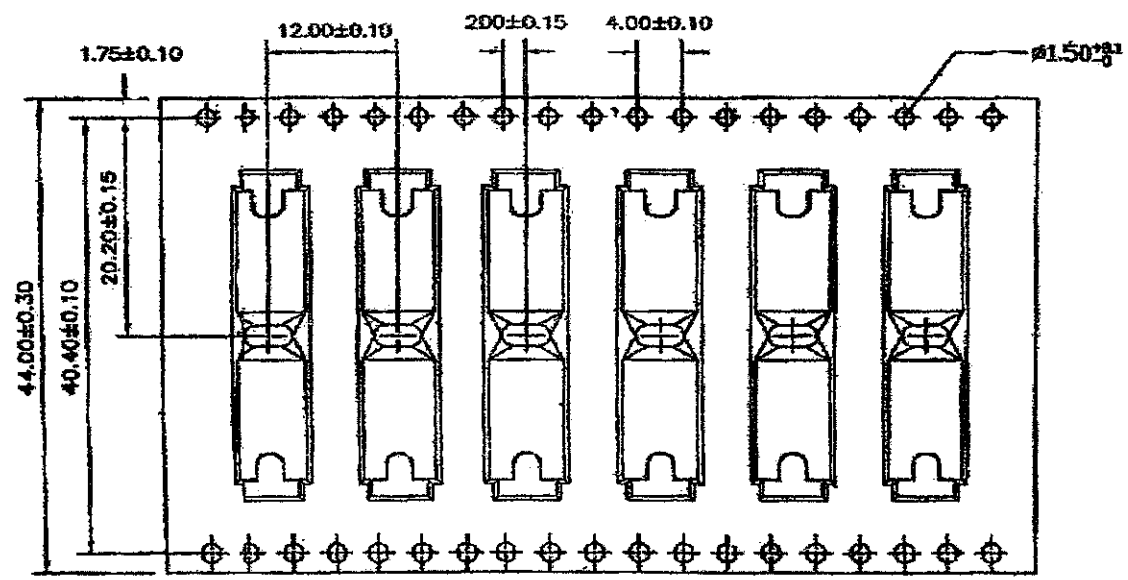

W	44.00±0.30
A0	5.30±0.10
B0	30.00±0.10
K0	5.20±0.10

- 10 sprockethole pitch cumulative tolerance ± 0.20
- Carrier camber is within 1 mm in 250mm.
- Material : Black Conductive Polystyrene Alloy.
- All dimensions meet EIA-481-C requirements.
- Thickness : 0.40 ± 0.05 mm.
- Packing length per 22" reel : 37.8 Meters,
Component load per 13" reel : 1000 pcs.12.6m.

				DATE	2007.01.27
				APPROVE	
COVER	REEL	UNIT	SCALE	AUDITING	
		mm		DESIGN	Donghua

SHOGYO INTERNATIONAL CORP.
#BC-2003
 BATTERY CLIP