

SPECIFICATION

- (1) ITEM NO: BH-9V-1/T
- (2) WITH 6 PRONG SNAP TERMINAL
- (3) TERMINAL: 0.5MM BRASS TIN PLATED
- (4) MATERIAL: NYLON RESIN, BLACK COLOR

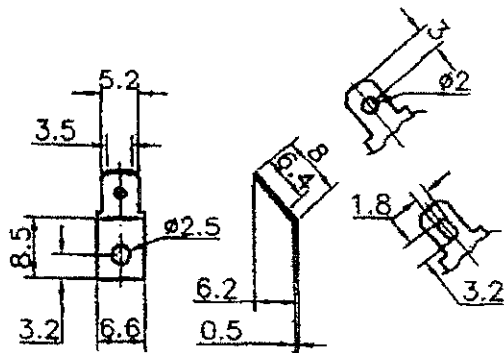

TERMINAL

3		
2		
△	Stud/socket symbol of battery modified	04.16.07
NO.	MODIFICATION	DATE

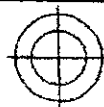

THIRD ANGLE PROJECTION

SCALE	1:1
UNIT	MM
MAT' L	AS SPEC.
DATE	AUG. 16, 2004

<b>SHOGYO INTERNATIONAL CORP.</b>
<b>#BH-9V-1/T</b>
BATTERY HOLDER