

SECTION: A-A

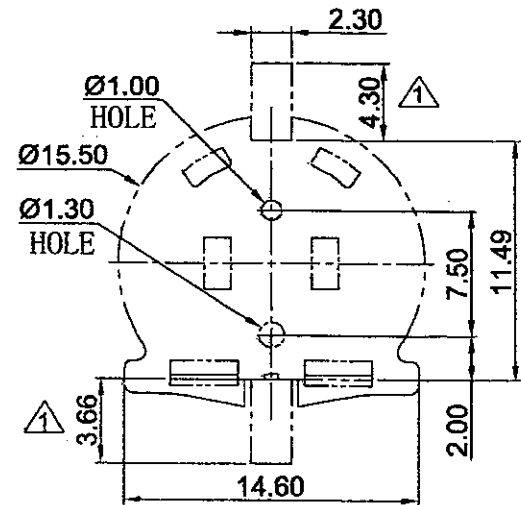

PCB MOUNTING LAYOUT

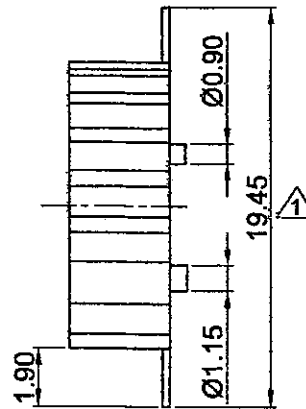
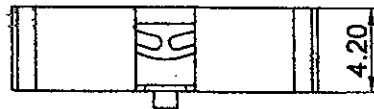

NOTES:

1. MATERIAL:

HOUSING : PPS UL 94V0

CONTACT : PHOSPHOR BRONZE 0.2 THK
GOLD PLATED OVER NICKEL

2. CONTACT RESISTANCE : 30 MILLIOHMS MAX

3. INSULATION RESISTANCE : 1000 MEGA OHMS MIN

4. DIELECTRIC VOLTAGE : 500V ONE SEC LEVEL

5. OPERATING TEMPERATURE : -55 °C ~ 105 °C

6. RoHS COMPLIANT

3		
2		
△	Corrected the drawing dimensions to match the merchandise	Dec/31 /2009
NO.	MODIFICATION	DATE
General Tolerance		
Dim: 0.0 ± 0.30		
0.00 ± 0.20		
Angle: ± 3° 0.000 ± 0.10		

SCALE	3:1
UNIT	MM
MAT'L	AS NOTES
DATE	NOV. 07. 2008

SHOGYO INTERNATIONAL CORP.
#CH291-1220LF
COIN CELL HOLDER