

SECTION A-A

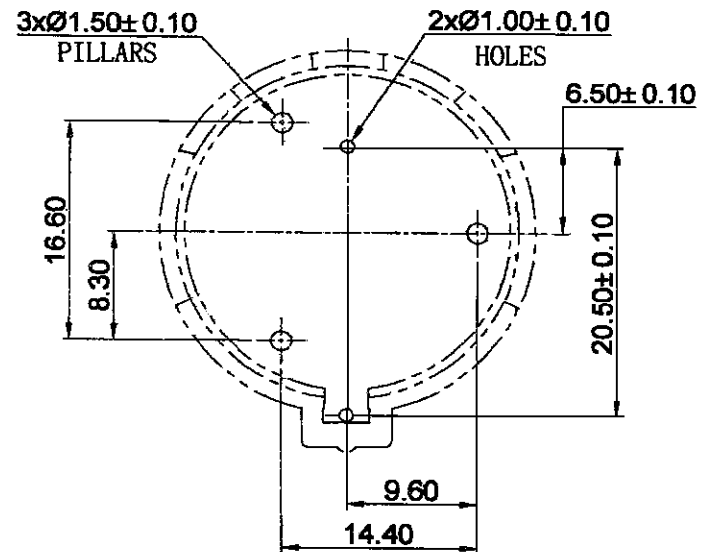

PCB MOUNTING LAYOUT

NOTES:

1. MATERIAL:  
HOUSING: NYLON 66 UL94V0 BLACK COLOR  
CONTACT: PHOSPHOR BRONZE 0.60MM THK  
TIN PLATED OVER NICKEL
2. CURRENT RATING : 3A (AC/DC)
3. VOLTAGE RATING : 500V (AC/DC)
4. CONTACT RESISTANCE: 100 MILLIOHMS
5. INSULATION RESISTANCE: 100 MEGAOHMS
6. TEMPERATURE RANGE: -40°C TO +105°C
7. HUMIDITY: 40°C AND 90-95% RH FOR 96 HOURS
8. RoHS COMPLIANT

3				
2				
1				
NO.	MODIFICATION	DATE	SCALE	2:1
			UNIT	MM
			MAT'L	AS NOTES
			DATE	MAR. 25. 2008

		General Tolerance Dim: 0.0 ±0.30 0.00 ±0.20 Angle: ±3° 0.000 ±0.10	
---	--	---	--

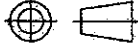
**SHOGYO INTERNATIONAL CORP.**  
**# CH002-2425LF**  
 COIN CELL HOLDER