

SECTION A-A

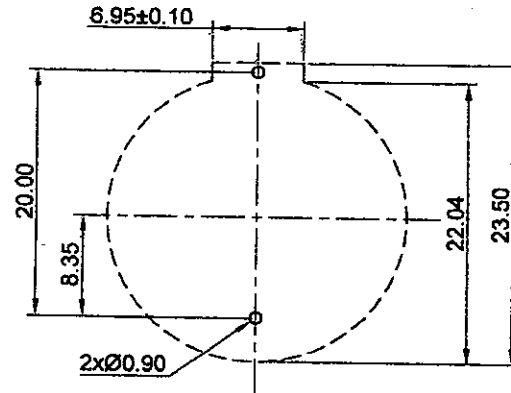

PCB MOUNTING LAYOUT

NOTES:

1. MATERIAL:  
 HOUSING : NYLON 66+15%GF UL94V0 BLACK COLOR  
 CONTACT : PHOSPHOR BRONZE 0.35MM THK  
 TIN PLATED OVER NICKEL
2. CURRENT RATING : 2A (AC/DC)
3. VOLTAGE RATING : 500V (AC/DC)
4. CONTACT RESISTANCE : 30 MILLIOHMS
5. INSULATION RESISTANCE : 1000 MEGAOHMS
6. TEMPERATURE RANGE : -55°C TO +105°C
7. HUMIDITY : 40°C AND 90-95% RH FOR 96 HOURS
8. RoHS COMPLIANT

3		
2		
1		
NO.	MODIFICATION	DATE
General Tolerance Dim: 0 ±0.30 0.00 ±0.20 Angle: ±3° (0.00 ±0.10)		

SCALE	2:1
UNIT	MM
MAT'L	AS NOTES
DATE	NOV. 15. 2010

**SHOGYO INTERNATIONAL CORP.**  
**#CH251-2032LF**  
 COIN CELL HOLDER