

SECTION A-A

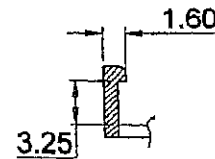

SECTION B-B

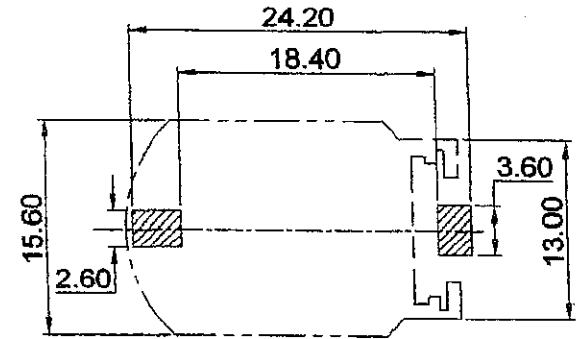

PCB MOUNTING LAYOUT

NOTES:

1. MATERIAL:

HOUSING:PPS 30%GF UL94V0 BROWN COLOR  
 CONTACT:PHOSPHOR BRONZE 0.25 THK  
 GOLD 1um PLATED OVER Ni 5um MIN

2. CURRENT RATING : 3A (AC/DC)
3. VOLTAGE RATING : 250V (AC/DC)
4. CONTACT RESISTANCE: 30 MILLIOHMS
5. INSULATION RESISTANCE: 1000 MEGAOHMS
6. TEMPERATURE RANGE: -55°C TO +85°C
7. HUMIDITY: 40°C AND 90-95% RH FOR 96 HOURS
8. RoHS COMPLIANT

3		
	Added tolerance	Sep/13/10
	Dimension changed from 4.7 to 5.3	Sep/8/05
NO.	MODIFICATION	DATE
	General Tolerance	
	Dim:0.0	±0.30
	0.00	±0.20
	Angle:±3°	0.000 ±0.10

SCALE	2:1
UNIT	MM
MAT'L	AS NOTES
DATE	MAR. 25. 2008

<b>SHOGYO INTERNATIONAL CORP.</b>
<b>#CH7410-2032LF</b>
COIN CELL HOLDER