

BOTTOM

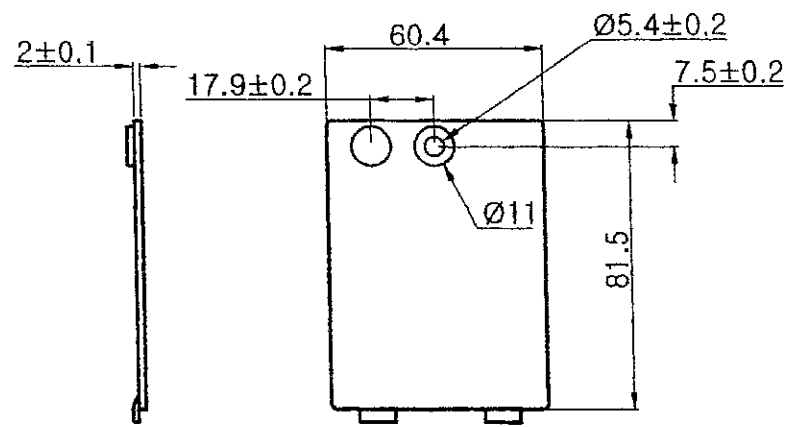

COVER

SPECIFICATION

- (1) ITRM NO: SBH-341-4AS
- (2) WIRE : UL1007 AWG26#
BLACK & RED 150MM ± 5MM
STRIP & TIN : 5MM ± 1MM
- (3) MATERIAL : ABS RESIN BLACK COLOR
- (4) SPRING : 0.7MM 65C SPRING WIRE
- (5) SWITCH: PB-4058B-R
- (6) ROHS COMPLIANT

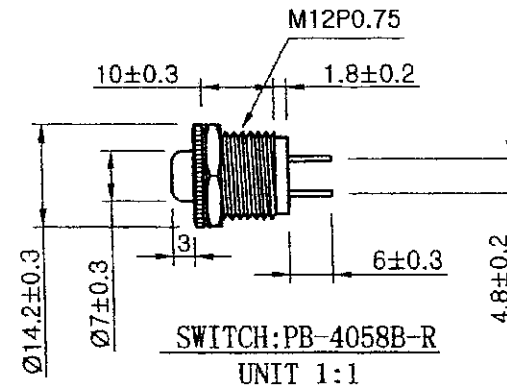

3		
2		
1		
NO.	MODIFICATION	DATE
<p>THIRD ANGLE PROJECTION</p>		

SCALE	1:2
UNIT	MM
MAT' L	ABS
DATE	OCT. 29. 2006

SHOGYO INTERNATIONAL CORP.
#SBH-341-4AS
BATTERY HOLDER