

A

B

C

E

(1)Resistance to soldering heat test.

The jack terminal shall be dipped in solder under the condition as specified below.

(a)The terminal for a printed circuit board :

Temperature of solder : 225°C±5°C Dip time : 5±1 seconds

(b)The terminal for a lead wire : Temperature of solder : 350°C±10°C

Dip time : 3±0.5 seconds

(2)Test Condition : (a)Solder time : 3±0.5sec

(b)Solder pot : 230±5°C

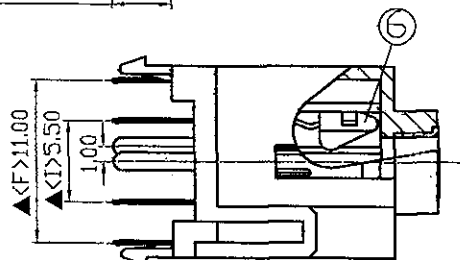
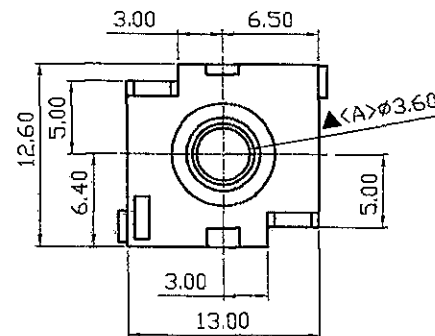
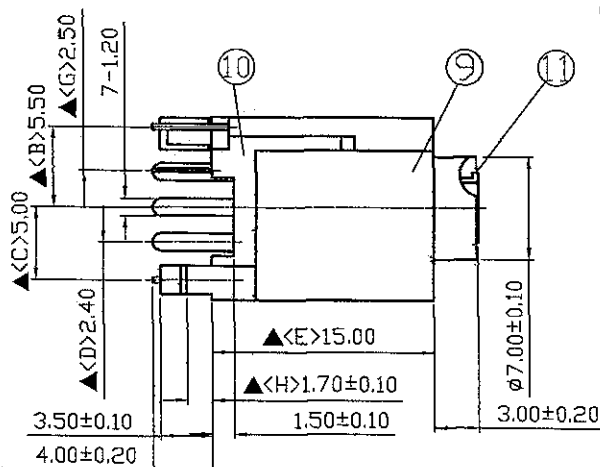
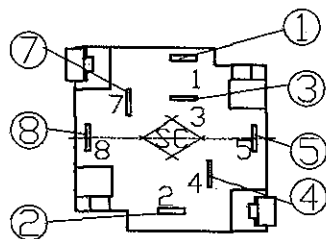

RoHS
Compliant

SPECIFICATIONS:

Contact Resistance : 30mΩ max
 Insulation Resistance : 100MΩ min. at DC 500V
 Dielectric Withstand Voltage : AC 500V for one minute
 Remark: ▲: The Most Important Dimension

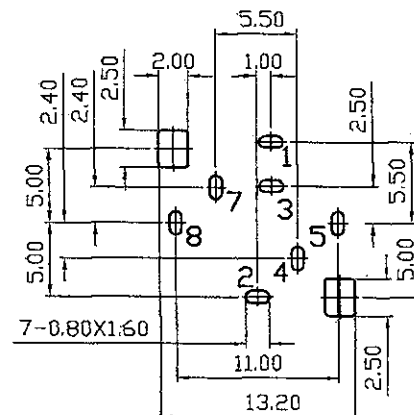

Pin Hole Layout
(Jack Bottom View)

11.	Barrel	Brass	1	Nickel Plated
10.	Back Cover	PBT+15%G	1	Black Color
9.	Housing	PBT	1	Black Color
8.	Break Terminal	0.25T Phosphor Bronze	1	Silver Plated
7.	Separator Terminal	0.3T Brass	1	Silver Plated
6.	Insulator	POM	2	White Color
5.	Break Terminal	0.25T Phosphor Bronze	1	Silver Plated
4.	Separator Spring	0.3T Brass	1	Silver Plated
3.	Ring Spring	0.25T Phosphor Bronze	1	Silver Plated
2.	Tip Spring	0.35T Phosphor Bronze	1	Silver Plated
1.	Earth Spring	0.25T Phosphor Bronze	1	Silver Plated
NO.	Description	Material	Q'TY	Finish

DATE	DWN	CHKD
01.06.2012		

PART NAME : 3.5φ PHONE JACK

TOLERANCE : ±0.3mm UNLESS OTHERWISE SPECIFIED

UNIT:mm

SHOGYO INTERNATIONAL CORP.

SCJ340R0N(*)S0B00G