

WASHER

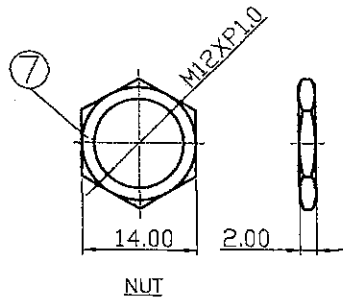

NUT

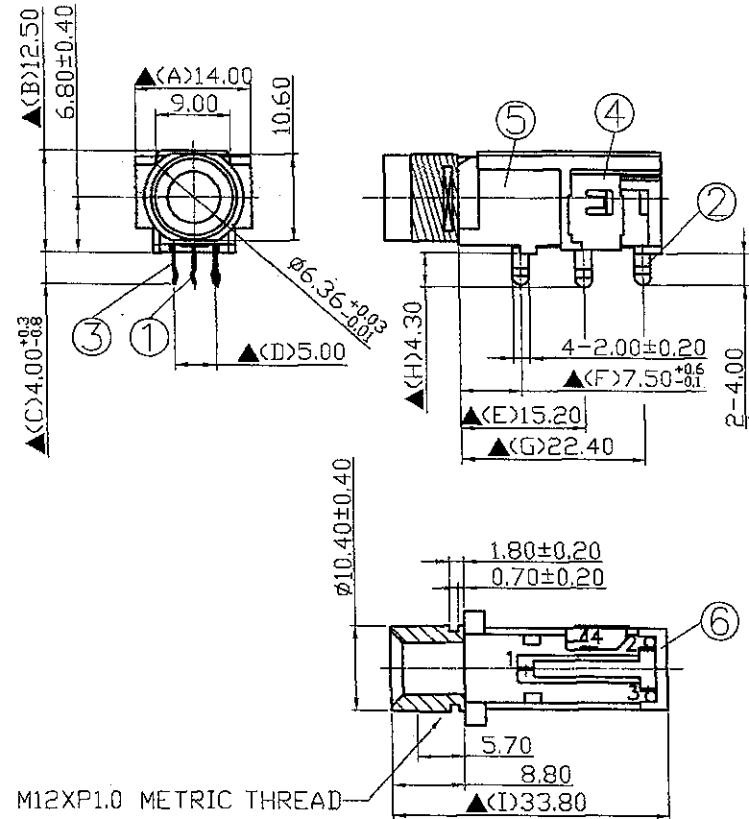
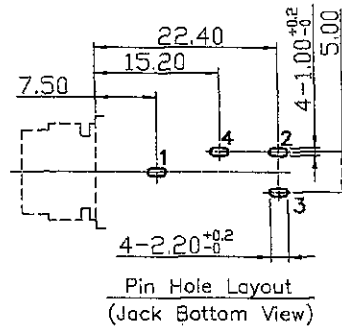

M12XP1.0 METRIC THREAD

8.	Washer	0.5T Iron	1	Nickel Plated
7.	Nut	2.0T Iron	1	Nickel Plated
6.	Cover	PBT	1	Black Color
5.	Housing	PBT	1	Black Color
4.	Tip Shunt	0.3T Brass	1	Silver Plated
3.	Ring Spring	0.3T Phosphor Bronze	1	Silver Plated
2.	Tip Spring	0.4T Phosphor Bronze	1	Silver Plated
1.	Earth Terminal	0.3T Phosphor Bronze	1	Silver Plated
NO	Description	Material	Q'TY	Finish

DATE	DWN	CHKD
10.12.2011		

PART NAME : 6.3φ PHONE JACK

TOLERANCE : ±0.3mm UNLESS OTHERWISE SPECIFIED

UNIT:mm

RoHS
Compliant

SPECIFICATIONS:

Contact Resistance : 30mΩ max
 Insulation Resistance : 100MΩ min. at DC 500V
 Dielectric Withstanding Voltage: AC 500V for one minute
 Remark: ▲: The Most Important Dimension

SHOGYO INTERNATIONAL CORP.

SCJ630P50(*)S1BK0G