

WASHER

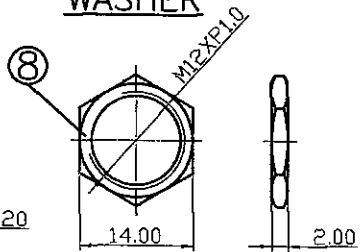

NUT

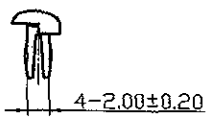

DETAIL "A"(2:1)

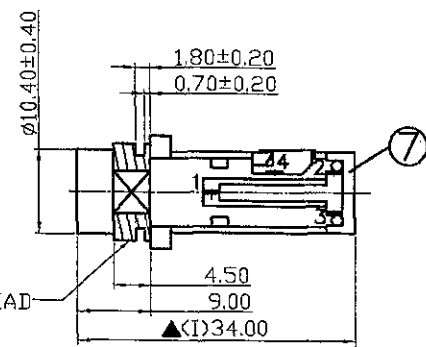

M12XP1.0 METRIC THREAD

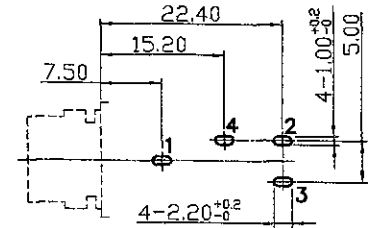

Pin Hole Layout  
(Jack Bottom View)

NO	Description	Material	Q'TY	Finish
9.	Washer	0.5T Steel	1	Nickel Plated
8.	Nut	2.0T Steel	1	Nickel Plated
7.	Cover	PBT	1	Black Color
6.	Housing	PBT	1	Black Color
5.	Bushing	Brass	1	Nickel Plated
4.	Tip Shunt	0.3T Brass	1	Silver Plated
3.	Ring Spring	0.3T Phosphor Bronze	1	Silver Plated
2.	Tip Spring	0.4T Phosphor Bronze	1	Silver Plated
1.	Earth Terminal	0.3T Phosphor Bronze	1	Silver Plated

DATE	DWN	CHKD
10.12.2011		

PART NAME : 6.3φ PHONE JACK

TOLERANCE : ±0.3mm UNLESS OTHERWISE SPECIFIED

UNIT:mm

RoHS Compliant

SPECIFICATIONS:  
 Contact Resistance : 30mΩ max  
 Insulation Resistance : 100MΩ min. at DC 500V  
 Dielectric Withstanding Voltage: AC 500V for one minute  
 Remark: ▲: The Most Important Dimension

**SHOGYO INTERNATIONAL CORP.**  
 # SCJ630R0N(\*)S1BH0G