

SCHMATIC	
MODEL NO	U

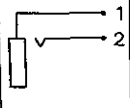

Pin Hole Layout
(Jack Bottom View)

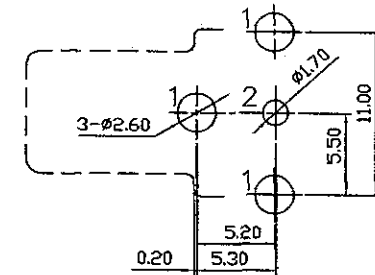
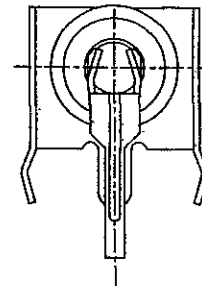
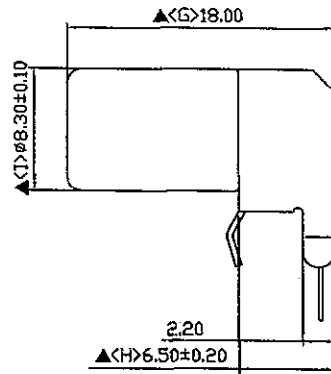
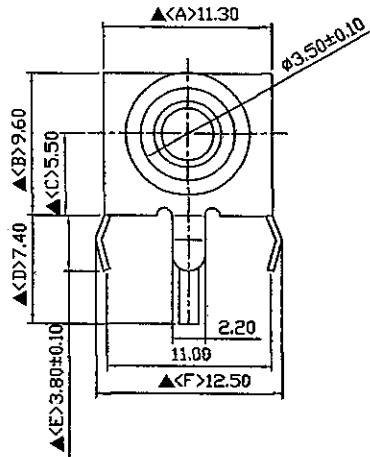
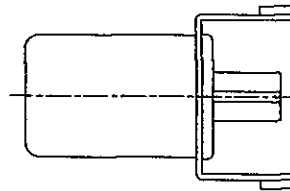
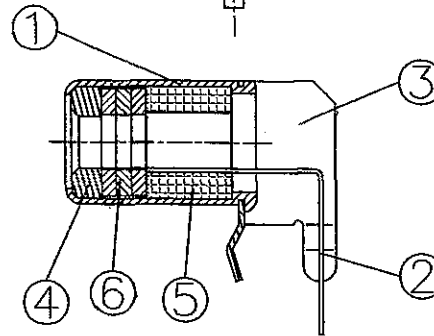

6.	Insulator	Bakelite	3	Natural
5.	Insulator	PBT	1	Black Color
4.	Insulator	PBT	1	Black Color
3.	Body	0.4T Steel	1	Tin Plating
2.	Terminal	0.25T Brass	1	Tin Plating
1.	Barrel(Sleeve)	0.3T Steel	1	Nickel Plated
NO.	Description	Material	Q'TY	Finish

DATE	DWN	CHKD
12.09.2005		

PART NAME : PIN JACK

TOLERANCE : $\pm 0.3\text{mm}$ UNLESS OTHERWISE SPECIFIED

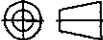
UNIT: mm 

RoHS
Compliant

For Reference
僅供參考

SPECIFICATIONS:

Contact Resistance : $30\text{m}\Omega$ max
 Insulation Resistance : $100\text{M}\Omega$ min. at DC 500V
 Dielectric Withstanding Voltage: AC 500V for one minute
 Remark: ▲: The Most Important Dimension

SHOGYO INTERNATIONAL CORP.

SCP612UNT1T0000G