

SCHEMATIC	
MODEL NO	U

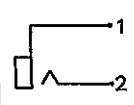
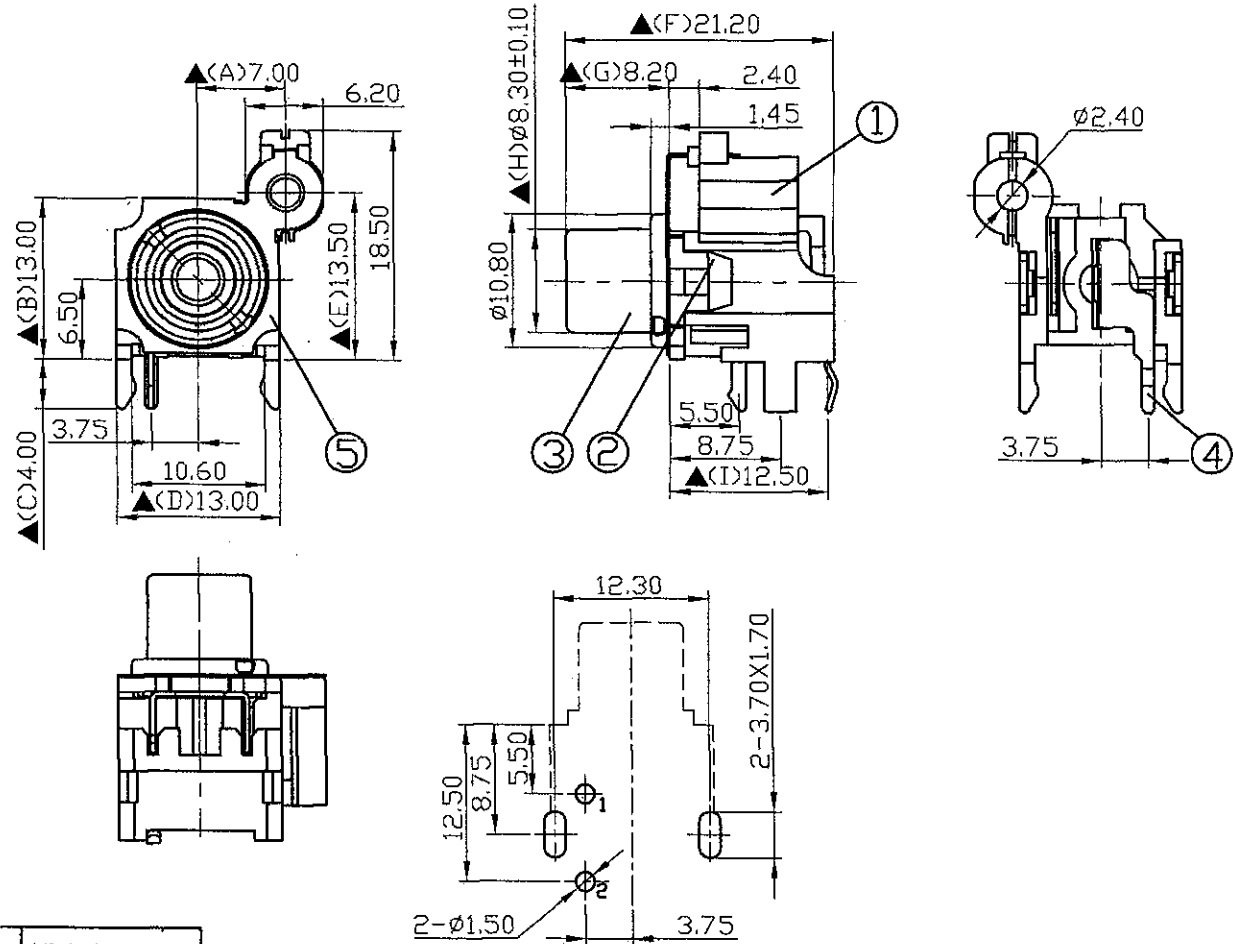

Pin Hole Layout
(Jack Bottom View)

NO.	Description	Material	Q'TY	Finish
5.	Earth1 Terminal	0.2T Bronze	1	Nickel Plated
4.	Terminal	0.4T Bronze	1	Silver Plated
3.	Outer Contact	0.4T Bronze	1	Nickel Plated
2.	Cover	ABS	1	Black Color
1.	Housing	ABS	1	Black Color

DATE	DWN	CHKD
09.05.2006		

PART NAME : PIN JACK

TOLERANCE : $\pm 0.3\text{mm}$ UNLESS OTHERWISE SPECIFIED

UNIT: mm



RoHS
Compliant

For Reference
僅供參考

SPECIFICATIONS:
 Contact Resistance : $30\text{m}\Omega$ max
 Insulation Resistance : $100\text{M}\Omega$ min. at DC 500V
 Dielectric Withstand Voltage : AC 500V for one minute
 Remark: ▲ : The Most Important Dimension

SHOGYO INTERNATIONAL CORP.

SCP617UNS1N0000G