

SHOGYO INTERNATIONAL CORP.

www.shogyo.com

SPEAKER SPECIFICATIONS

MODEL NO.	GA0401X (RoHS)				
1	NOMINAL SIZE	40 mm	1-1/2 inch		
2	IMPEDANCE	8 Ω ± 15%	at. 800 Hz	1 V	
3	RESONANCE FO	620 Hz ± 124 Hz	FO Hz	1 V	
4	S.P. LEVEL	78 dB/w ± 3 dB	0.2 W 50 cm average at		
5	FREQ. RESPONSE	Fo Hz ~ 8K Hz			
6	INPUT POWER	Nominal Input 0.2 W	Handling Capacity 0.5 W		
7	OPERATION	Must be normal at program source 0.2 W			
8	BUZZ, RATTLE, ETC.	Must be normal at Sine Wave 1.26 V			
9	MAGNET	13 x 10 mm			
10	FLUX DENSITY	Gauss ± 10%	total flux max well within		
11	TOTAL WEIGHT		gr	oz	
12	LOAD TEST	After test meets Item 7 and 8	White noise 0.2 W 24 Hours		
13	DISTORTION				
14	HEAT TEST	After test meets Item 7 and 8	60 ± 2° C 20-50 % R.H. 24 Hours		
15	HUMIDITY TEST	After test meet Item 7 and 8	40 ± 2° C 90-95 % R.H. 24 Hours		

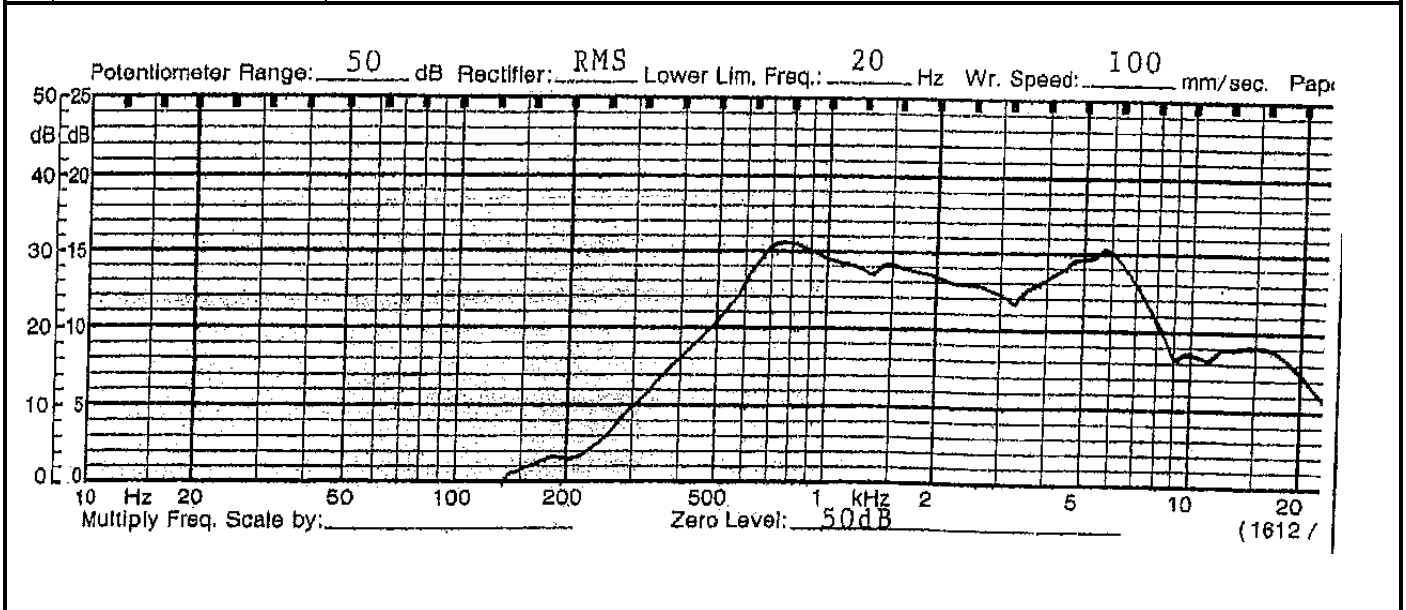

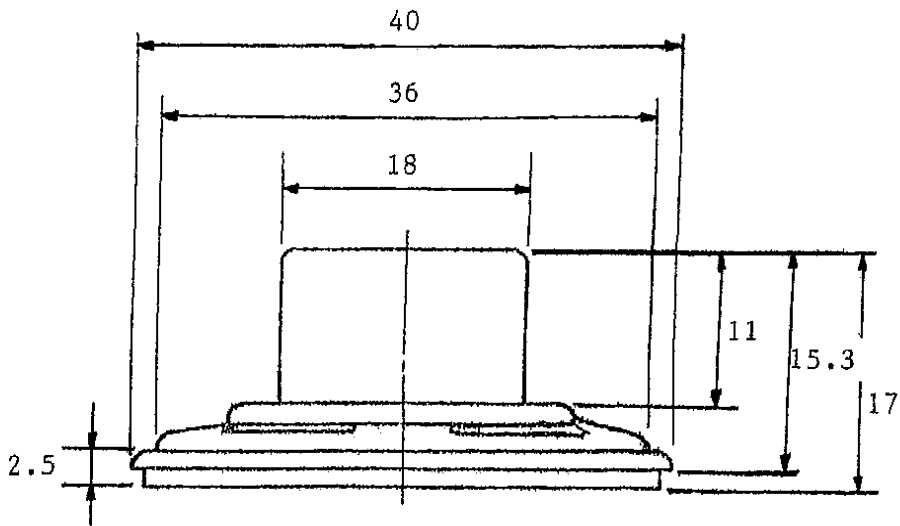
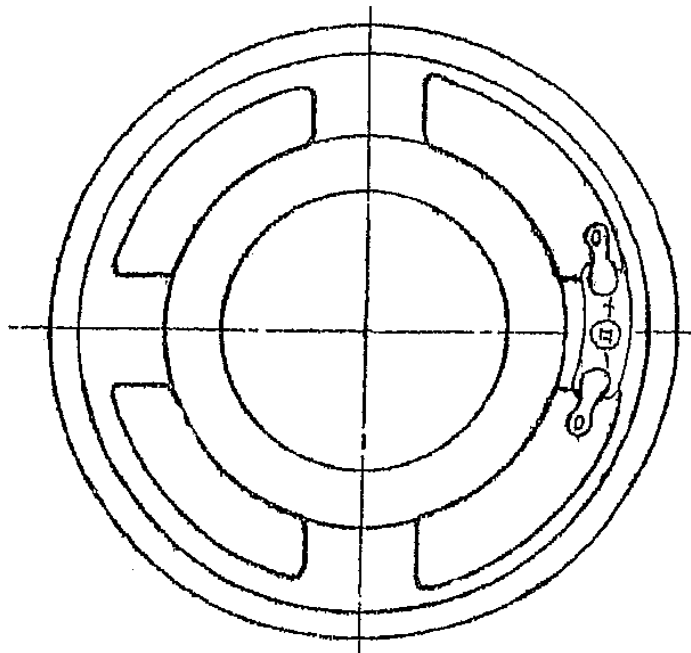

TOLERANCE: ± 0.5 MM

MODEL NO. GA0401X

APPROVED	CHECKED	DRAWING