

# SHOGYO INTERNATIONAL CORP.

www.shogyo.com

## SPEAKER SPECIFICATIONS

MODEL NO.	<b>GA0506M-1X (RoHS)</b>				
1	NOMINAL SIZE	50 mm	2	inch	
2	IMPEDANCE	8 $\Omega$ $\pm$ 15%	at.	800 Hz	1 V
3	RESONANCE FO	460 Hz $\pm$ 92 Hz	FO	Hz	1 V
4	S.P.L. LEVEL	83 dB/w $\pm$ 3 dB	0.25 W 50 cm average at		
5	FREQ. RESPONSE	Fo Hz ~ 10K Hz	1K, 1.4K, 1.7K, 2K Hz		
6	INPUT POWER	Rated power 0.25 W	Handling Capacity 0.5 W		
7	OPERATION	Must be normal at program source 0.25 W			
8	BUZZ, RATTLE, ETC.	Must be normal at Sine Wave 1.41 V			
9	MAGNET	13 x 6 mm			
10	FLUX DENSITY	Gauss $\pm$ 10%	total flux max well within		
11	DISTORTION				
12	LOAD TEST	After test meet Item 7 and 8	White noise 0.25 W 5 Hours		
13	OPERATION TEMP.				
14	HEAT TEST	After test meet Item 7 and 8	65 $\pm$ 2° C 20-50 % R.H. 5 Hours		
15	HUMIDITY TEST	After test meet Item 7 and 8	40 $\pm$ 2° C 90-95 % R.H. 5 Hours		

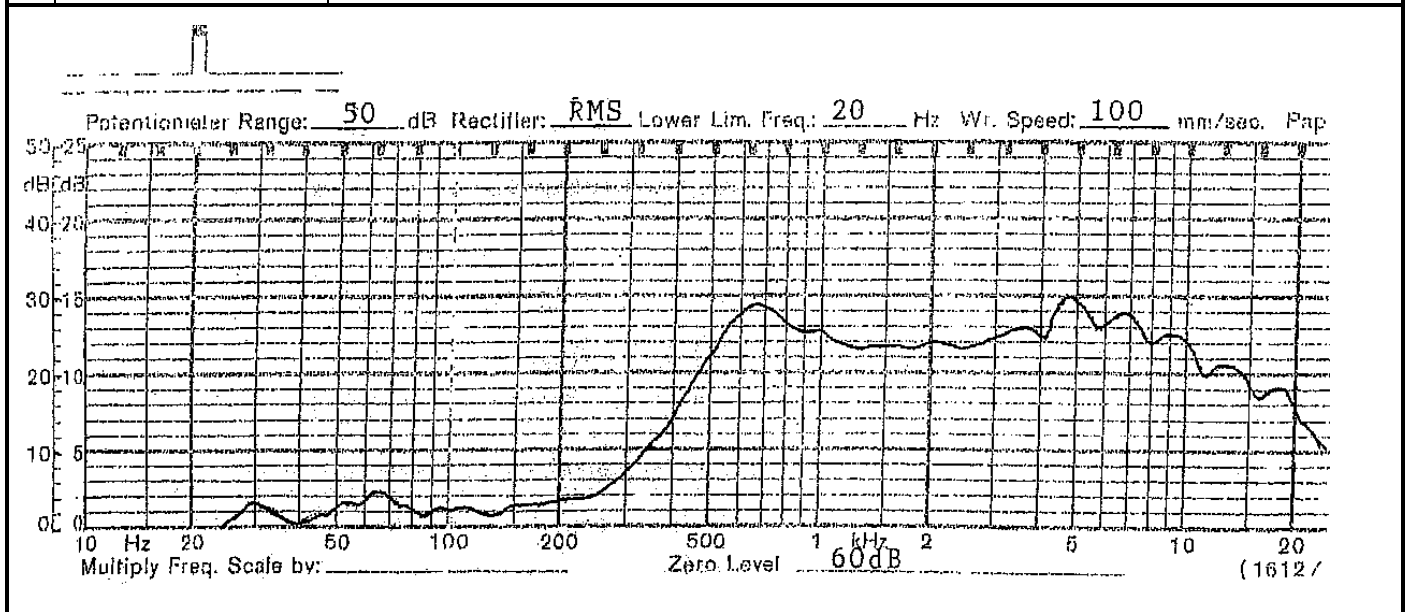

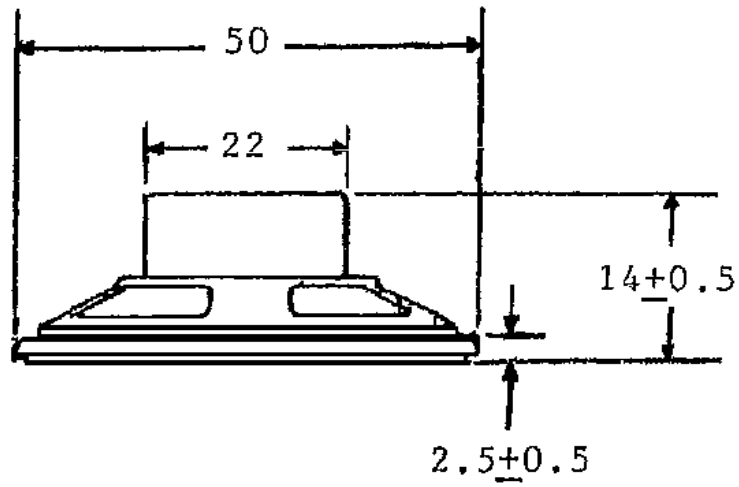
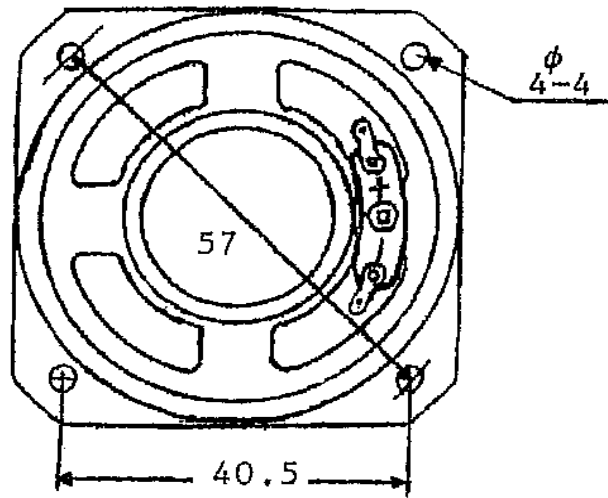

TOLERANCE :  $\pm 0.5\text{MM}$

MODEL NO.

**GA0506M-1X**

APPROVED

CHECKED

DRAWING