

SHOGYO INTERNATIONAL CORP.

www.shogyo.com

SPEAKER SPECIFICATIONS

MODEL NO.	GA0929X (RoHS)					
1	NOMINAL SIZE	60 x 90 mm	2-1/2 x 3-1/2	inch		
2	IMPEDANCE	8 Ω ± 15%	at. 800 Hz	1 V		
3	RESONANCE FO	300 Hz ± 60 Hz	FO Hz	1 V		
4	S.P. LEVEL	91 dB/w ± 3 dB	1 W 50 cm average at			
5	FREQ. RESPONSE	Fo Hz ~ 15K Hz				
6	INPUT POWER	Nominal Input 1 W	Handling Capacity 2 W			
7	OPERATION	Must be normal at program source 1 W				
8	BUZZ, RATTLE, ETC.	Must be normal at Sine Wave 2.83 V				
9	MAGNET	13 x 10 mm				
10	FLUX DENSITY	Gauss ± 10%	total flux max well within			
11	TOTAL WEIGHT		gr	oz		
12	LOAD TEST	After test meets Item 7 and 8	White noise 1 W 48 Hours			
13	DISTORTION					
14	HEAT TEST	After test meets Item 7 and 8	70 ± 2° C 20-50 % R.H. 48 Hours			
15	HUMIDITY TEST	After test meet Item 7 and 8	40 ± 2° C 90-95 % R.H. 48 Hours			

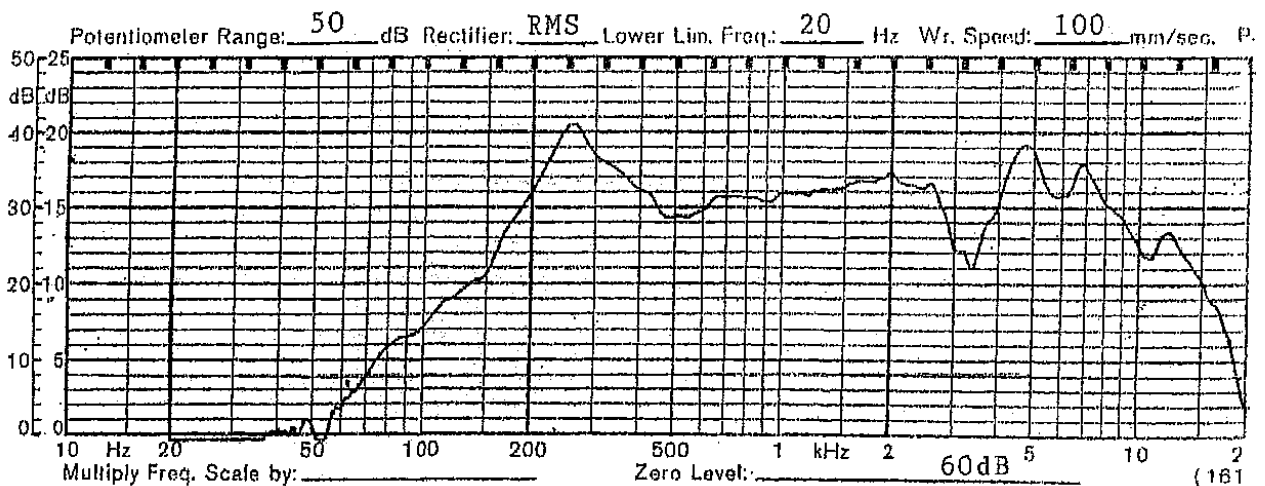

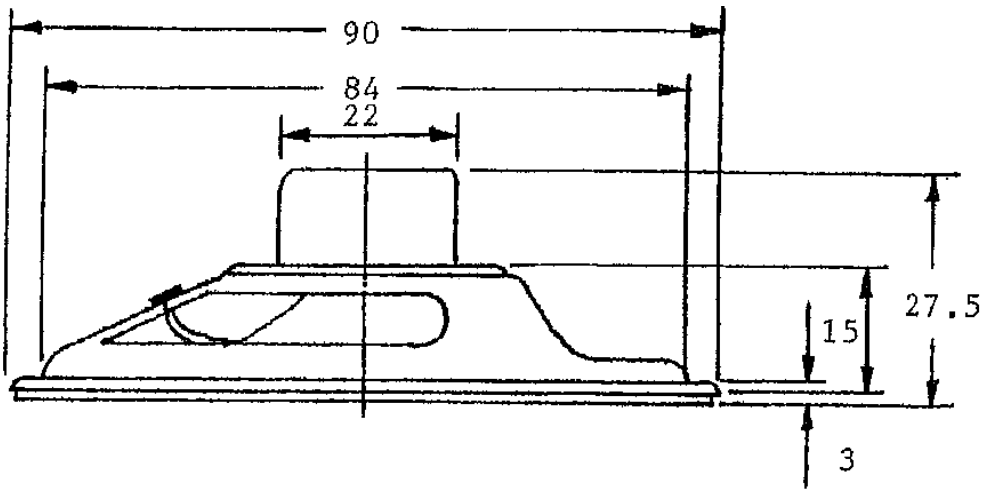
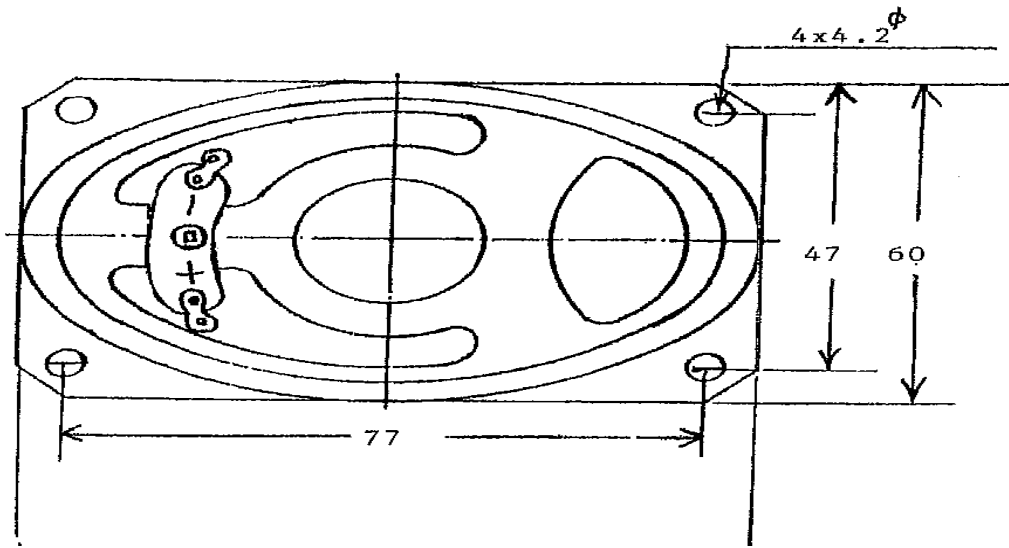

TOLERANCE: ± 0.8 MM

MODEL NO. GA0929X

APPROVED	CHECKED	DRAWING