

# SHOGYO INTERNATIONAL CORP.

www.shogyo.com

## SPEAKER SPECIFICATIONS

<b>MODEL NO.</b>	<b>GC0286MAPX (RoHS)</b>				
<b>1</b>	<b>NOMINAL SIZE</b>	<b>28 mm</b>	<b>inch</b>		
<b>2</b>	<b>IMPEDANCE</b>	<b>8 Ω ± 15%</b>	<b>at. 1K Hz</b>	<b>1 V</b>	
<b>3</b>	<b>RESONANCE FO</b>	<b>600 Hz ± 120 Hz</b>	<b>FO Hz</b>	<b>1 V</b>	
<b>4</b>	<b>S.P. LEVEL</b>	<b>82 dB/w ± 3 dB</b>	<b>1 W 50 cm average at</b>		
<b>5</b>	<b>FREQ. RESPONSE</b>	<b>Fo Hz ~ 20K Hz</b>	<b>MAX 10 dB</b>	<b>600, 800, 1K, 1.2K Hz</b>	
<b>6</b>	<b>INPUT POWER</b>	Nominal Input <b>1 W</b>	Handling Capacity <b>2 W</b>		
<b>7</b>	<b>OPERATION</b>	Must be normal at program source <b>1 W</b>			
<b>8</b>	<b>BUZZ, RATTLE, ETC.</b>	Must be normal at Sine Wave <b>2.83 V</b>			
<b>9</b>	<b>MAGNET</b>	<b>11.5 x 1.5 mm</b>			
<b>10</b>	<b>FLUX DENSITY</b>	<b>Gauss ± 10%</b>	<b>total flux max well within</b>		
<b>11</b>	<b>TOTAL WEIGHT</b>	gr	oz		
<b>12</b>	<b>LOAD TEST</b>	After test meets Item 7 and 8	White noise <b>1 W 24 Hours</b>		
<b>13</b>	<b>DISTORTION</b>				
<b>14</b>	<b>HEAT TEST</b>	After test meets Item 7 and 8	<b>60 ± 2° C 20-50 % R.H. 24 Hours</b>		
<b>15</b>	<b>HUMIDITY TEST</b>	After test meet Item 7 and 8	<b>40 ± 2° C 90-95 % R.H. 24 Hours</b>		

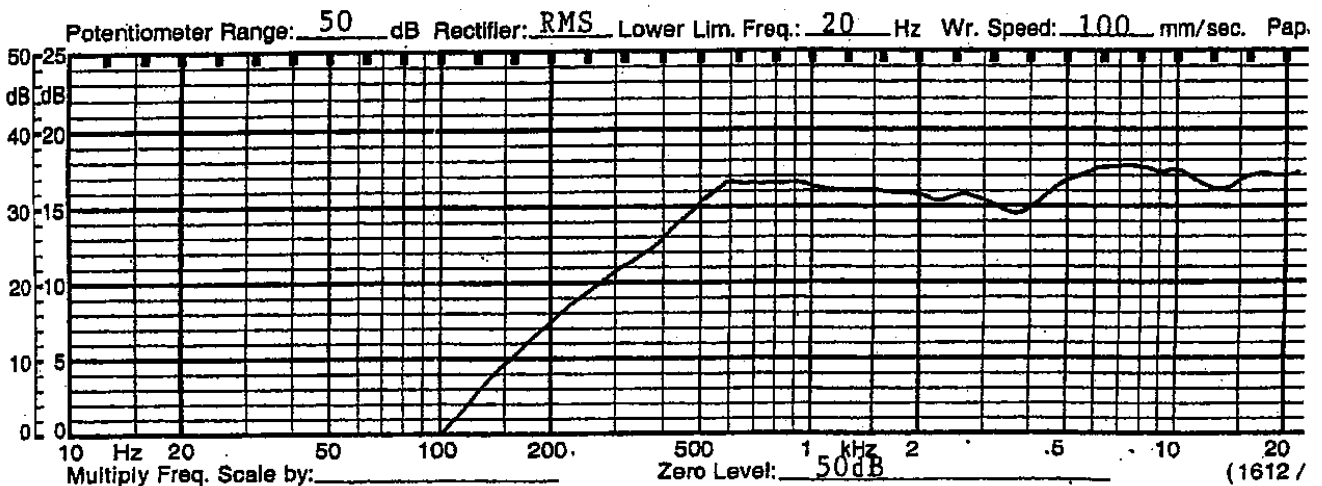

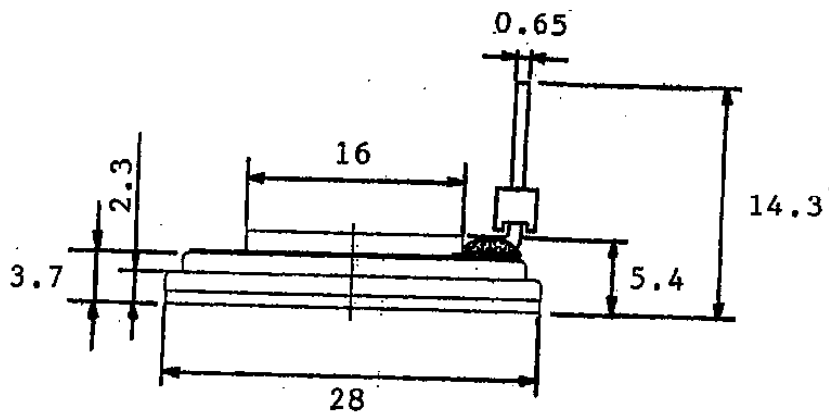
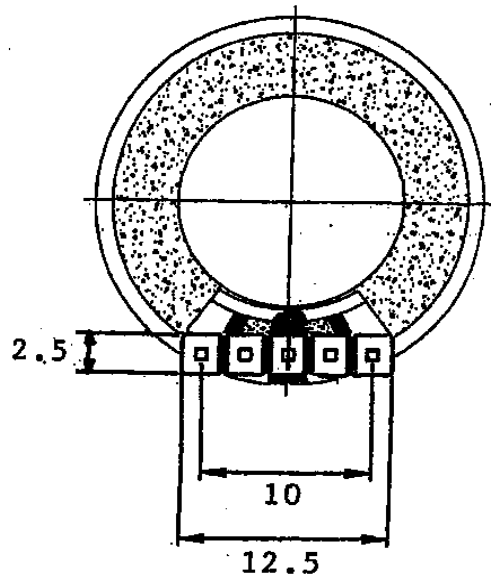

**TOLERANCE:  $\pm 0.3$  MM**

**MODEL NO.**

**GC0286MAPX**

APPROVED

CHECKED

DRAWING