

SHOGYO INTERNATIONAL CORP.

www.shogyo.com

SPEAKER SPECIFICATIONS

MODEL NO.	GC0401HLX (RoHS)				
1	NOMINAL SIZE	40 mm	inch		
2	IMPEDANCE	8 Ω ± 15%	at. 1K Hz	1 V	
3	RESONANCE FO	230 Hz ± 46 Hz	FO Hz	1 V	
4	S.P. LEVEL	90 dB/w ± 3 dB	1 W 50 cm average at		
5	FREQ. RESPONSE	Fo Hz ~ 20K Hz	MAX 10 dB	300, 400, 500, 600 Hz	
6	INPUT POWER	Nominal Input 2 W	Handling Capacity 4 W		
7	OPERATION	Must be normal at program source 2 W			
8	BUZZ, RATTLE, ETC.	Must be normal at Sine Wave 4 V			
9	MAGNET	12.5 x 3.0 mm			
10	FLUX DENSITY	Gauss ± 10%	total flux max well within		
11	TOTAL WEIGHT		gr	oz	
12	LOAD TEST	After test meets Item 7 and 8	White noise 2 W 24 Hours		
13	DISTORTION				
14	HEAT TEST	After test meets Item 7 and 8	65 ± 2° C 20-50 % R.H. 24 Hours		
15	HUMIDITY TEST	After test meet Item 7 and 8	40 ± 2° C 90-95 % R.H. 24 Hours		

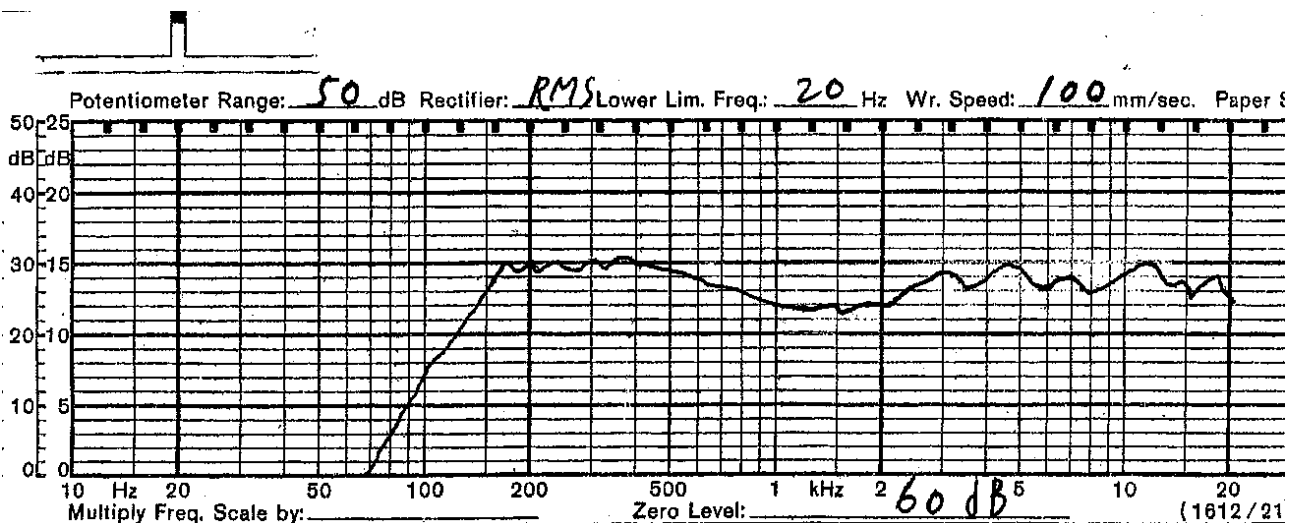

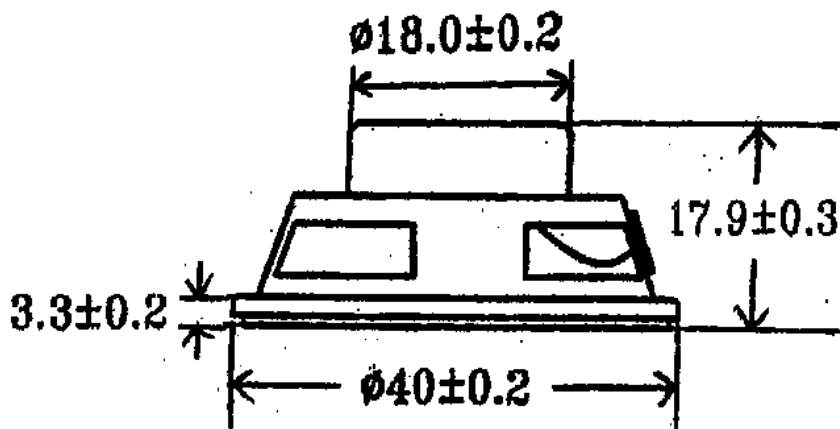
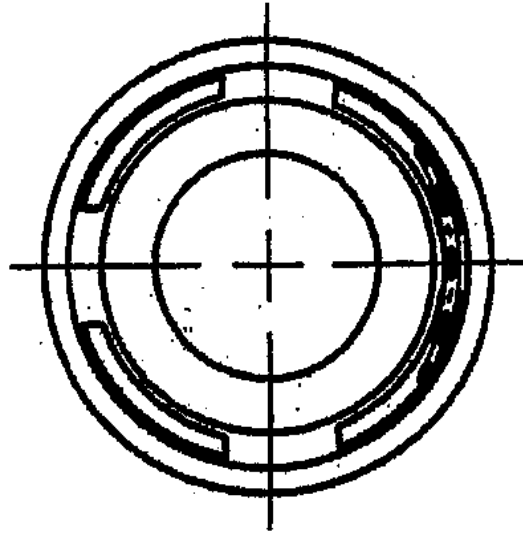

MODEL NO. GC0401HLX

APPROVED	CHECKED	DRAWING