

SHOGYO INTERNATIONAL CORP.

www.shogyo.com

SPEAKER SPECIFICATIONS

MODEL NO.	GC0401KL-3X (RoHS)					
1	NOMINAL SIZE	40.1 x 40.1 x 14.5H mm	inch	(MYLAR DUST CAP)		
2	IMPEDANCE	8 Ω ± 15%	at. 1K Hz	1 V		
3	RESONANCE FO	390 Hz ± 78 Hz	FO Hz	1 V		
4	S.P. LEVEL	87 dB/w ± 3 dB	1 W 50 cm average at			
5	FREQ. RESPONSE	Fo Hz ~ 20K Hz				
6	INPUT POWER	Nominal Input 5 W	Handling Capacity 8 W			
7	OPERATION	Must be normal at program source 5 W				
8	BUZZ, RATTLE, ETC.	Must be normal at Sine Wave 6.32 V				
9	MAGNET	24.5 x 3.5 mm				
10	FLUX DENSITY	Gauss ± 10%	total flux max well within			
11	TOTAL WEIGHT	gr	oz			
12	LOAD TEST	After test meets Item 7 and 8	White noise 5 W 24 Hours			
13	DISTORTION					
14	HEAT TEST	After test meets Item 7 and 8	60 ± 2° C 20-50 % R.H. 24 Hours			
15	HUMIDITY TEST	After test meet Item 7 and 8	40 ± 2° C 90-95 % R.H. 24 Hours			

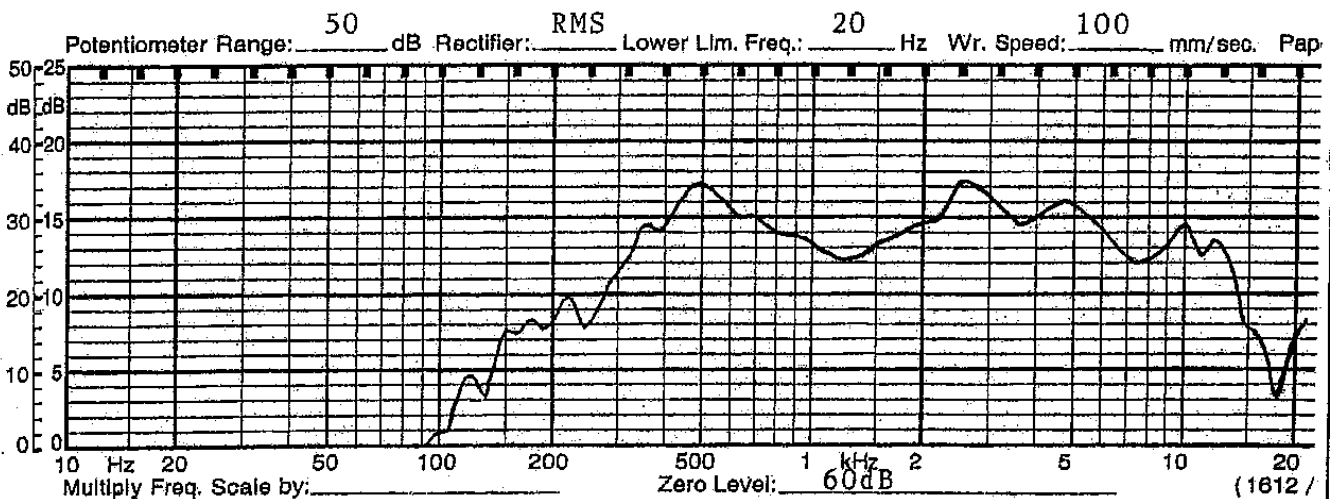

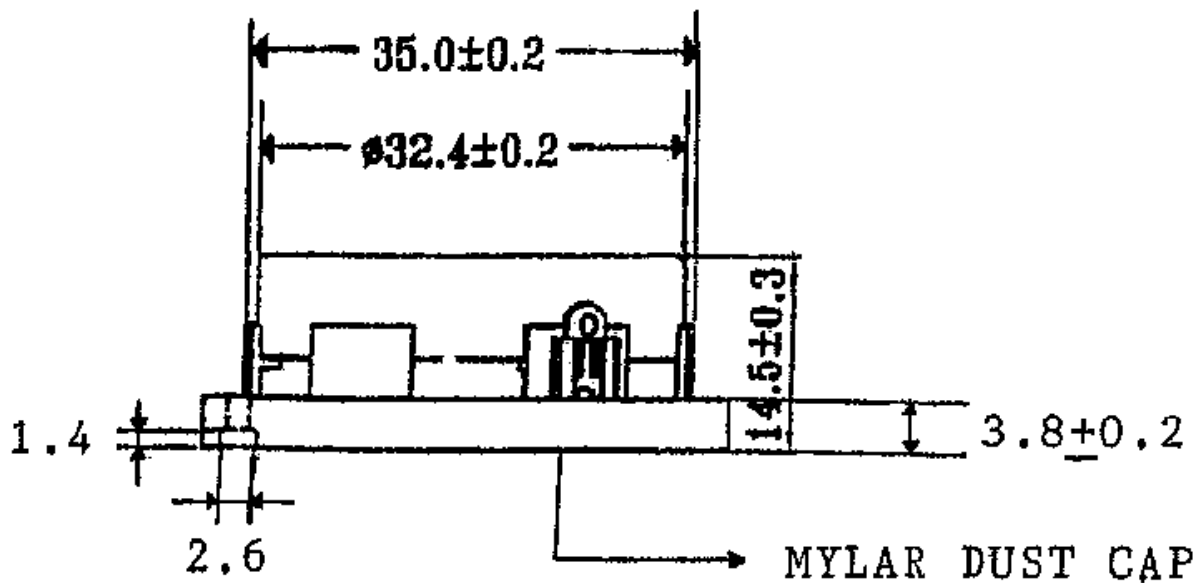
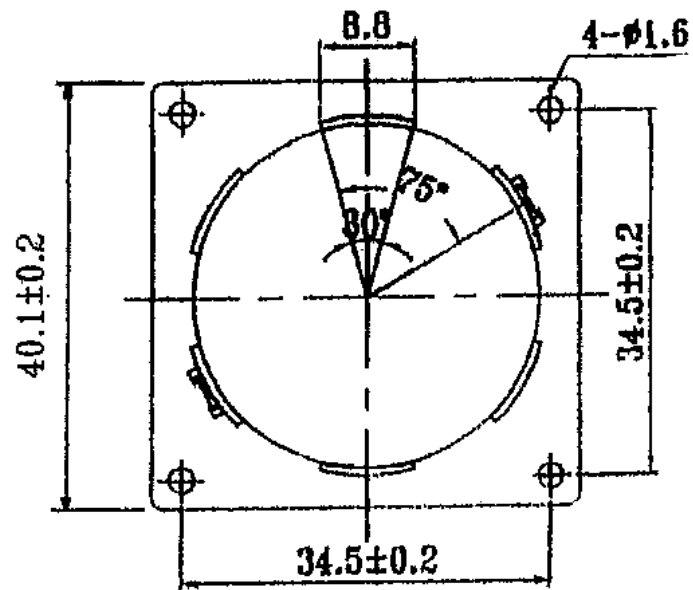

MODEL NO. GC0401KL-3X

APPROVED	CHECKED	DRAWING