

SHOGYO INTERNATIONAL CORP.

www.shogyo.com

SPEAKER SPECIFICATIONS

MODEL NO.	GC0401MX (RoHS)					
1	NOMINAL SIZE	40 mm	1-1/2 inch			
2	IMPEDANCE	8 Ω ± 15%	at 800 Hz	1 V		
3	RESONANCE FO	600 Hz ± 120 Hz	FO Hz	1 V		
4	S.P. LEVEL	80 dB/w ± 3 dB	0.2 W 50 cm average			
5	FREQ. RESPONSE	Fo Hz ~ 8K Hz	at 1K, 1.5K, 1.8K, 2K Hz			
6	INPUT POWER	Nominal Input 0.2 W	Handling Capacity 0.5 W			
7	OPERATION	Must be normal at program source 0.2 W				
8	BUZZ, RATTLE, ETC.	Must be normal at Sine Wave 1.26 V				
9	MAGNET	12.5 x 1.5 mm				
10	FLUX DENSITY	Gauss ± 10%	total flux max well within			
11	TOTAL WEIGHT	gr	oz			
12	LOAD TEST	After test meets Item 7 and 8	White noise 0.2 W 24 Hours			
13	DISTORTION					
14	HEAT TEST	After test meets Item 7 and 8	60 ± 2° C 20-50 % R.H. 24 Hours			
15	HUMIDITY TEST	After test meet Item 7 and 8	40 ± 2° C 90-95 % R.H. 24 Hours			

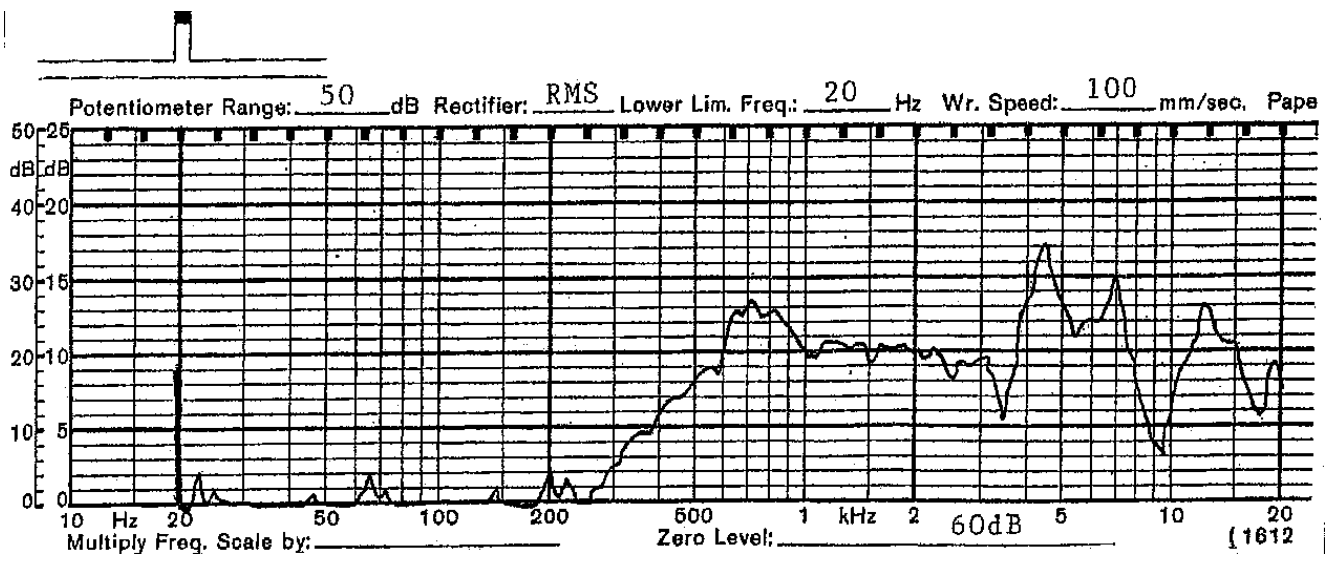

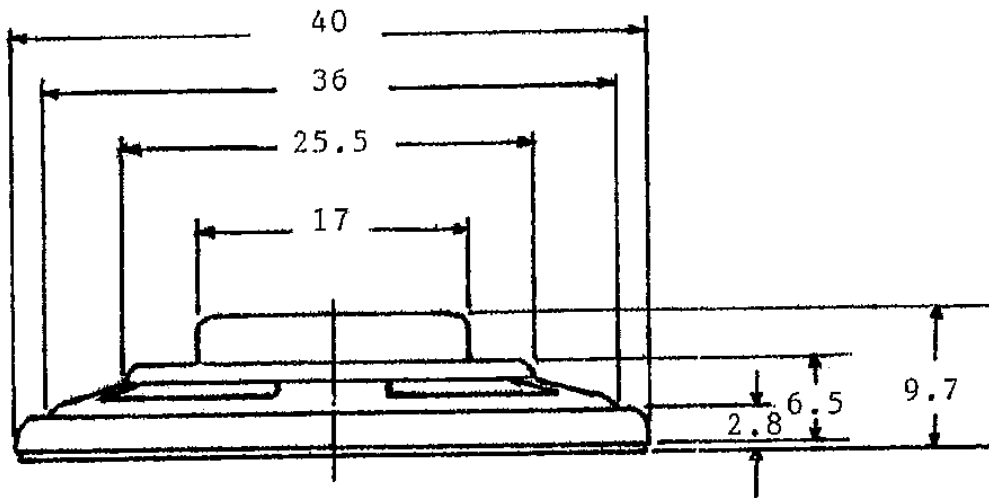
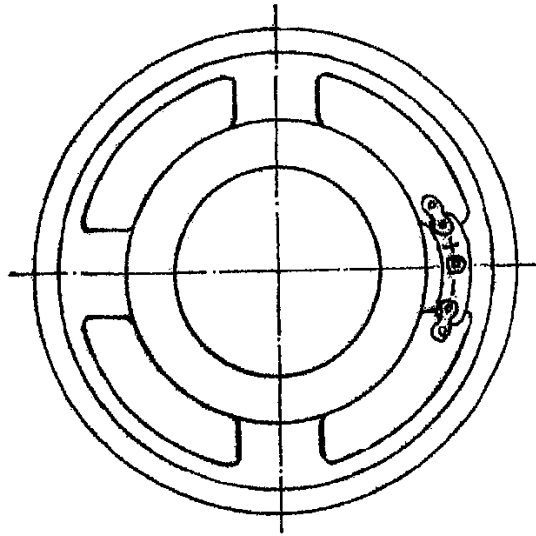

TOLERANCE: ± 0.5 MM

MODEL NO. GC0401MX

APPROVED	CHECKED	DRAWING