

SHOGYO INTERNATIONAL CORP.

www.shogyo.com

SPEAKER SPECIFICATIONS

MODEL NO.	GF0506X (RoHS)					
1	NOMINAL SIZE	50 mm	2 inch			
2	IMPEDANCE	8 Ω ± 15%	at. 800 Hz	1 V		
3	RESONANCE FO	430 Hz ± 86 Hz	FO Hz	1 V		
4	S.P. LEVEL	82 dB/w ± 3 dB	0.25 W 50 cm average at			
5	FREQ. RESPONSE	Fo Hz ~ 7.2K Hz				
6	INPUT POWER	Nominal Input 0.25 W	Handling Capacity 0.5 W			
7	OPERATION	Must be normal at program source 0.25 W				
8	BUZZ, RATTLE, ETC.	Must be normal at Sine Wave 1.41 V				
9	MAGNET	32 x 18 x 6 mm				
10	FLUX DENSITY	Gauss ± 10%	total flux max well within			
11	TOTAL WEIGHT	gr	oz			
12	LOAD TEST	After test meets Item 7 and 8	White noise 0.25 W 24 Hours			
13	DISTORTION					
14	HEAT TEST	After test meets Item 7 and 8	70 ± 2° C 20-50 % R.H. 24 Hours			
15	HUMIDITY TEST	After test meet Item 7 and 8	40 ± 2° C 90-95 % R.H. 24 Hours			

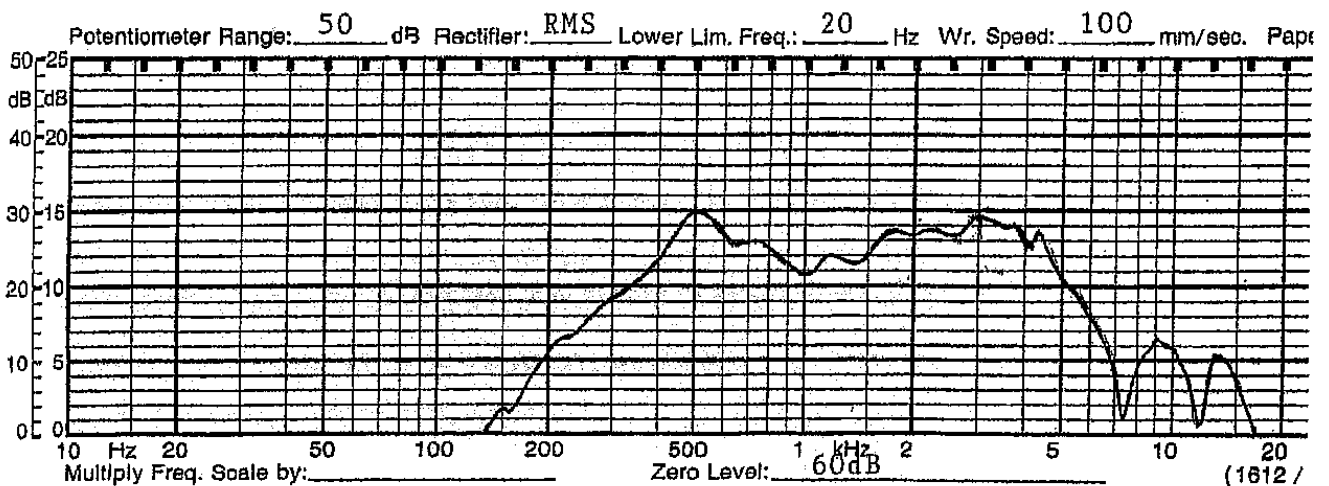

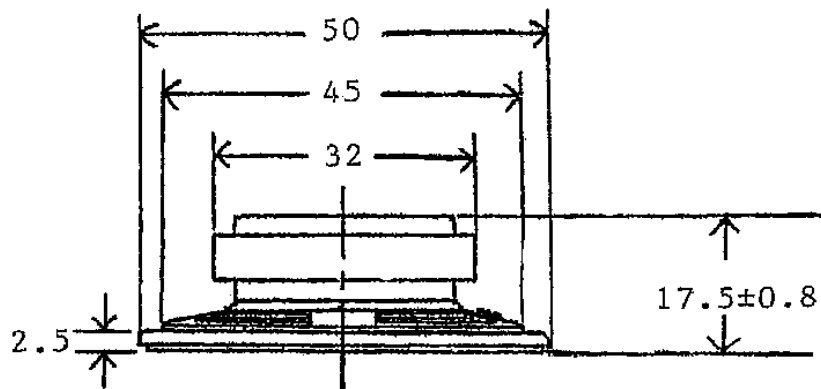
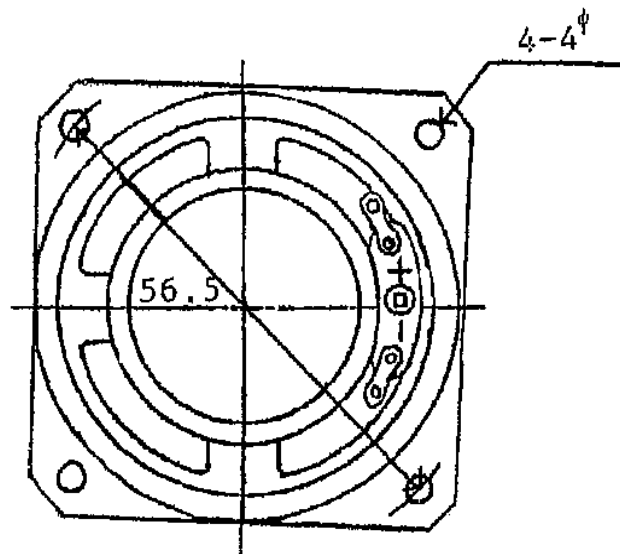

TOLERANCE: ± 0.8 MM

MODEL NO. GF0506X

APPROVED	CHECKED	DRAWING