

SHOGYO INTERNATIONAL CORP.

www.shogyo.com

SPEAKER SPECIFICATIONS

MODEL NO.	GF0573X (RoHS)					
1	NOMINAL SIZE	57 mm	2-1/4	inch		
2	IMPEDANCE	8 Ω ± 15%	at. 800 Hz	1 V		
3	RESONANCE FO	450 Hz ± 90 Hz	FO Hz	1 V		
4	S.P. LEVEL	92 dB/w ± 3 dB	1 W 50 cm average at 1K, 1.4K, 1.7K, 2K Hz			
5	FREQ. RESPONSE	Fo Hz ~ 20K Hz				
6	INPUT POWER	Nominal Input 3 W	Handling Capacity 5 W			
7	OPERATION	Must be normal at program source 3 W				
8	BUZZ, RATTLE, ETC.	Must be normal at Sine Wave 4.89 V				
9	MAGNET	45 x 22 x 8 mm				
10	FLUX DENSITY	Gauss ± 10%	total flux max well within			
11	TOTAL WEIGHT	gr	oz			
12	LOAD TEST	After test meets Item 7 and 8	White noise 3 W 24 Hours			
13	DISTORTION					
14	HEAT TEST	After test meets Item 7 and 8	70 ± 2° C 20-50 % R.H. 24 Hours			
15	HUMIDITY TEST	After test meet Item 7 and 8	40 ± 2° C 90-95 % R.H. 24 Hours			

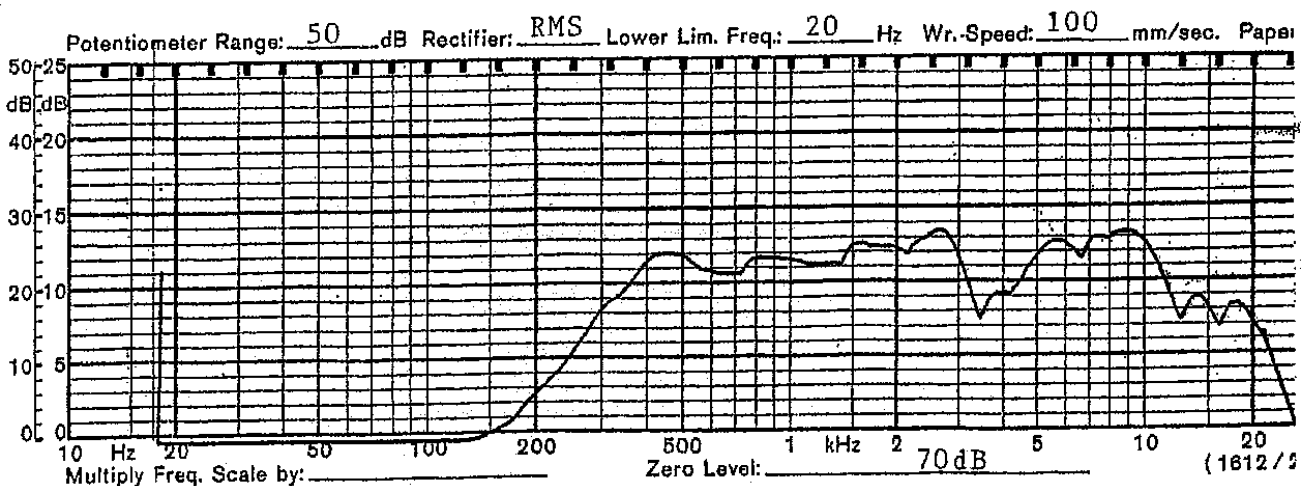

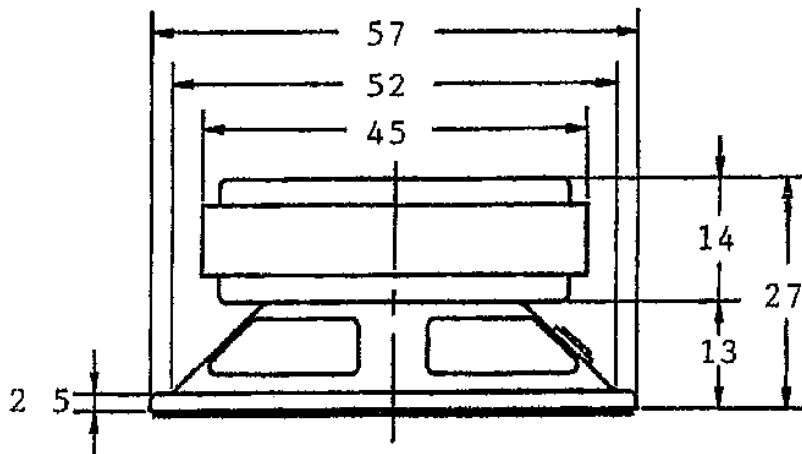
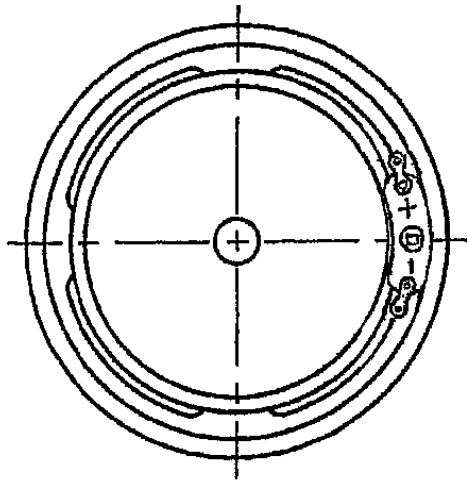

TOLERANCE: ± 0.8 MM

MODEL NO. GF0573X

APPROVED	CHECKED	DRAWING