

# SHOGYO INTERNATIONAL CORP.

www.shogyo.com

## SPEAKER SPECIFICATIONS

MODEL NO.	<b>GF0901X (RoHS)</b>				
<b>1</b>	NOMINAL SIZE	<b>51 x 91 mm</b>	<b>2 x 3-1/2</b>	<b>inch</b>	
<b>2</b>	IMPEDANCE	<b>8 Ω ± 15%</b>	<b>at. 1K Hz</b>	<b>1 V</b>	
<b>3</b>	RESONANCE FO	<b>230 Hz ± 46 Hz</b>	<b>FO Hz</b>	<b>1 V</b>	
<b>4</b>	S.P. LEVEL	<b>92 dB/w ± 3 dB</b>	<b>1 W 50 cm average at</b>		
<b>5</b>	FREQ. RESPONSE	<b>Fo Hz ~ 20K Hz</b>	<b>MAX</b>	<b>300, 400, 500, 600 Hz</b>	
			<b>10 dB</b>		
<b>6</b>	INPUT POWER	Nominal Input <b>3 W</b>	Handling Capacity <b>5 W</b>		
<b>7</b>	OPERATION	Must be normal at program source <b>3 W</b>			
<b>8</b>	BUZZ, RATTLE, ETC.	Must be normal at Sine Wave <b>4.8 V</b>			
<b>9</b>	MAGNET	<b>45 x 22 x 8 mm</b>			
<b>10</b>	FLUX DENSITY	<b>Gauss ± 10%</b>	<b>total flux max well within</b>		
<b>11</b>	TOTAL WEIGHT	<b>150 gr</b>	<b>oz</b>		
<b>12</b>	LOAD TEST	After test meets Item 7 and 8	<b>White noise 3 W 48 Hours</b>		
<b>13</b>	DISTORTION				
<b>14</b>	HEAT TEST	After test meets Item 7 and 8	<b>70 ± 2° C 20-50 % R.H. 48 Hours</b>		
<b>15</b>	HUMIDITY TEST	After test meet Item 7 and 8	<b>40 ± 2° C 90-95 % R.H. 48 Hours</b>		

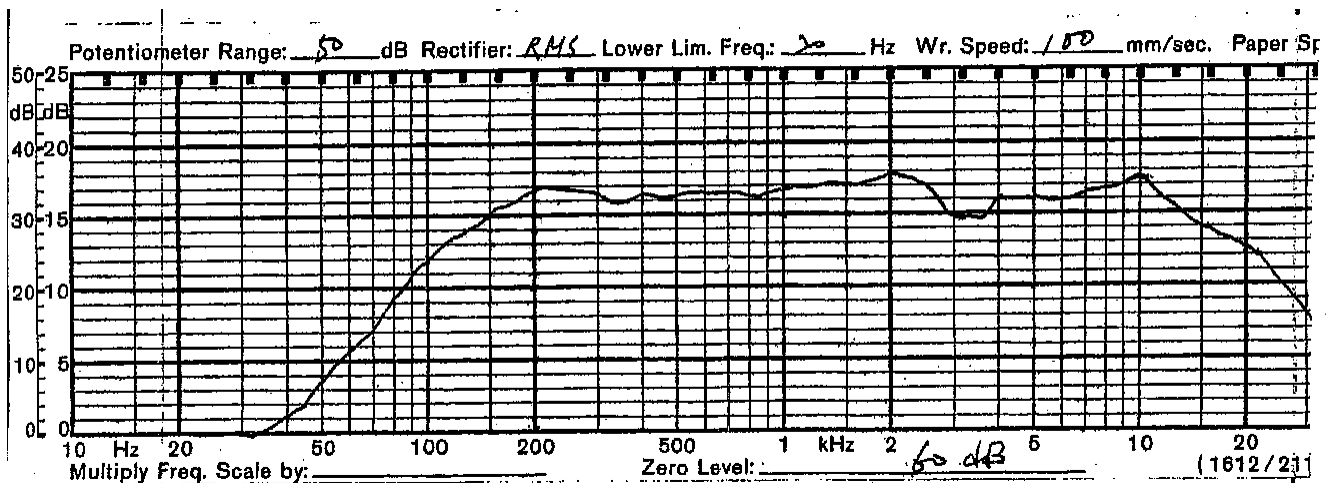

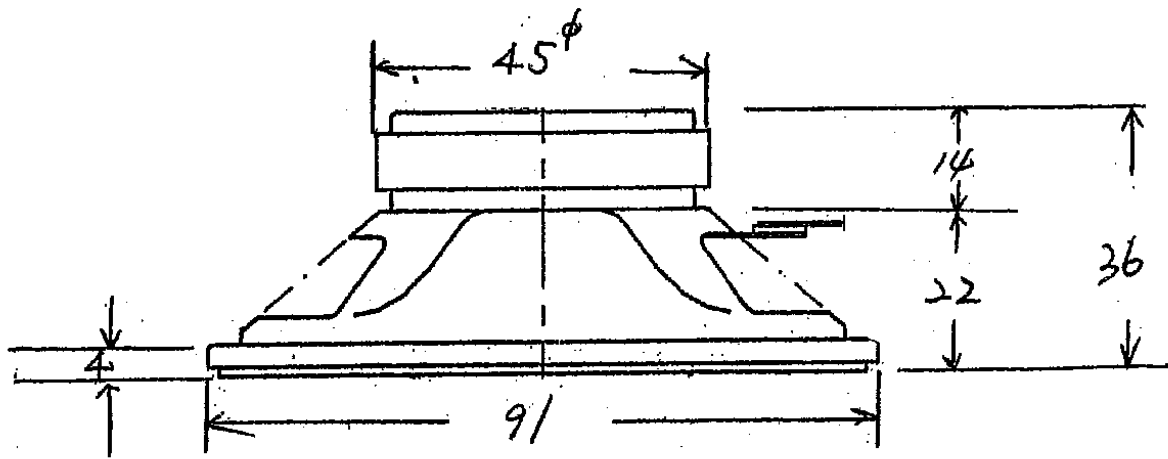
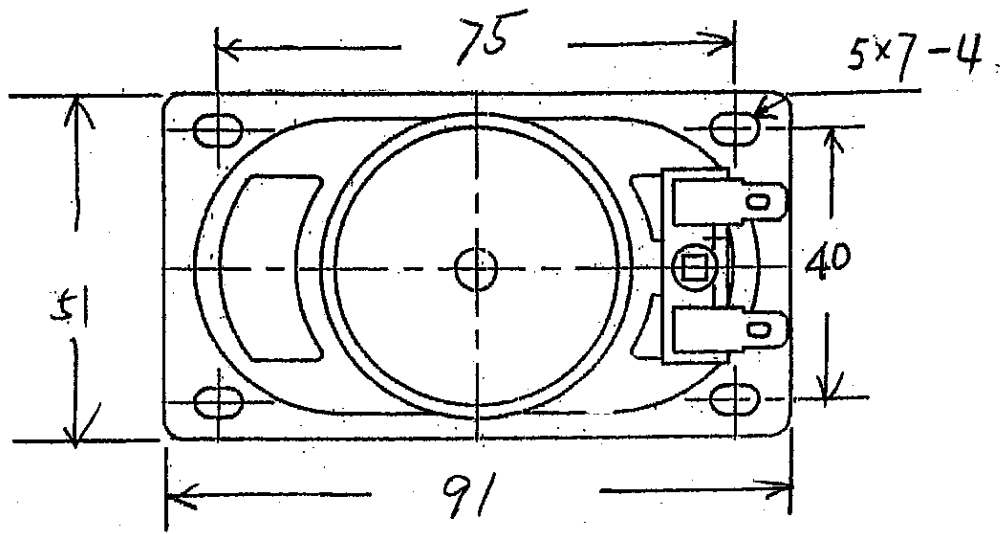

TOLERANCE:  $\pm 0.5$  MM

MODEL NO. GF0901X

APPROVED	CHECKED	DRAWING