

SHOGYO INTERNATIONAL CORP.

www.shogyo.com

SPEAKER SPECIFICATIONS

MODEL NO.	GF1004HX (RoHS)				
1	NOMINAL SIZE	102 mm	4	inch	
2	IMPEDANCE	8 Ω ± 15%	at. 400 Hz	1 V	
3	RESONANCE FO	100 Hz ± 15 Hz	FO Hz	1 V	
4	S.P. LEVEL	90 dB/w ± 2 dB	1 W 50 cm average at		
5	FREQ. RESPONSE	Fo Hz ~ 10K Hz	MAX 10 dB	300, 400, 500, 600 Hz	
6	INPUT POWER	Nominal Input 20 W	Handling Capacity 40 W		
7	OPERATION	Must be normal at program source 20 W			
8	BUZZ, RATTLE, ETC.	Must be normal at Sine Wave 8.9 V			
9	MAGNET	60 x 32 x 10 mm			
10	FLUX DENSITY	Gauss ± 10%	total flux max well within		
11	TOTAL WEIGHT		gr	oz	
12	LOAD TEST	After test meets Item 7 and 8	White noise 20 W 24 Hours		
13	DISTORTION				
14	HEAT TEST	After test meets Item 7 and 8	70 ± 2° C 20-50 % R.H. 24 Hours		
15	HUMIDITY TEST	After test meet Item 7 and 8	40 ± 2° C 90-95 % R.H. 24 Hours		

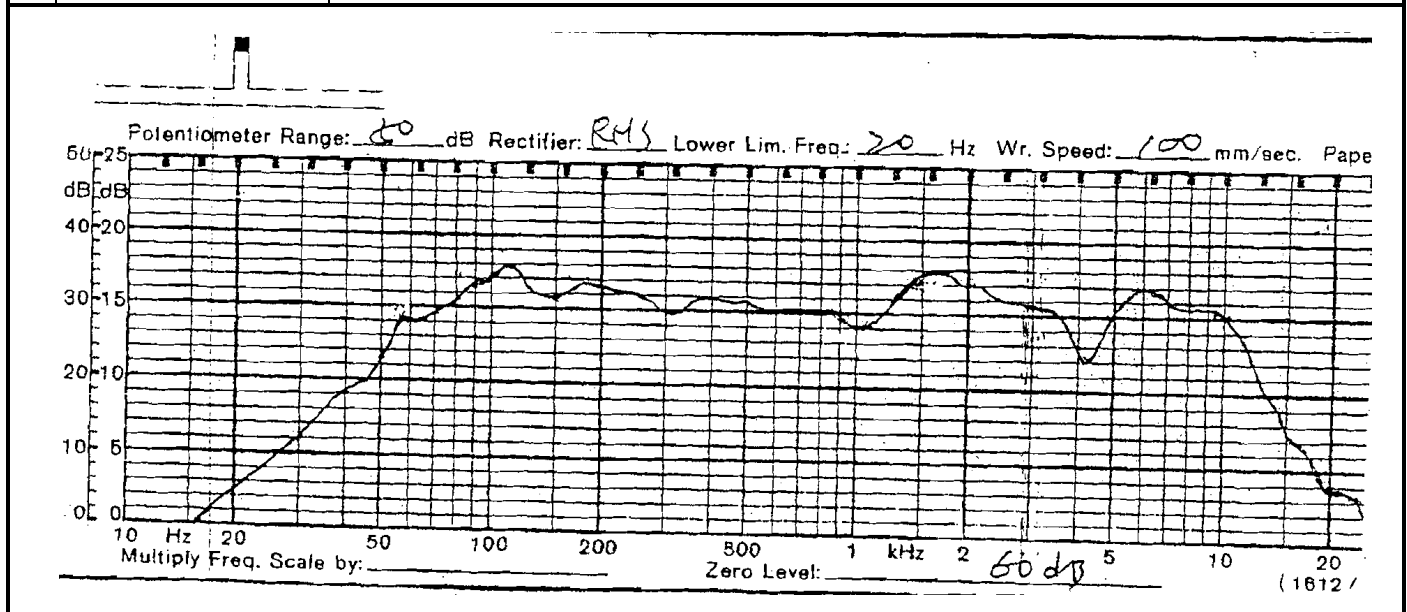

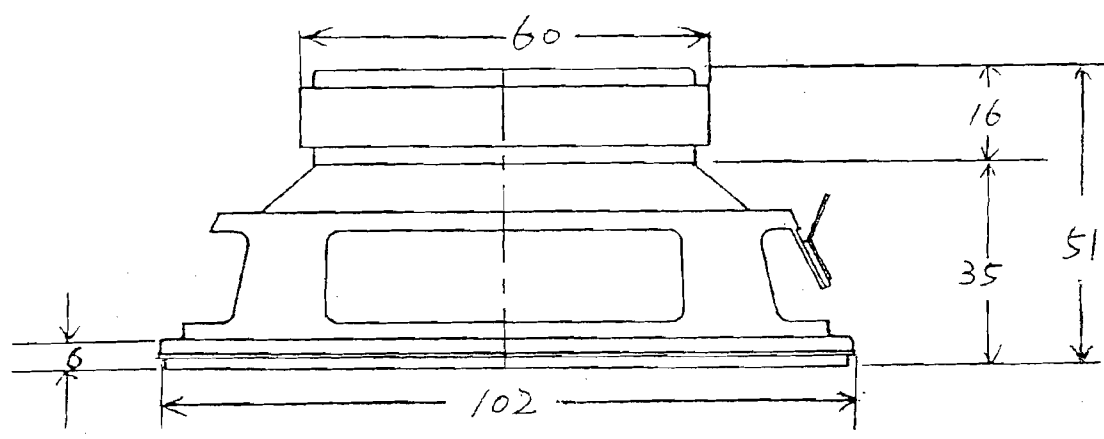
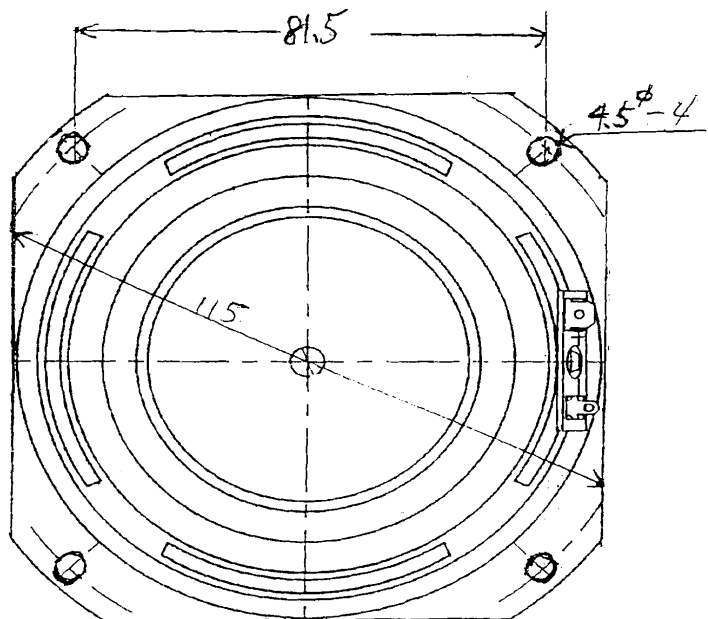

TOLERANCE: ± 0.5 MM

MODEL NO. GF1004HX		
APPROVED	CHECKED	DRAWING