

SHOGYO INTERNATIONAL CORP.

www.shogyo.com

SPEAKER SPECIFICATIONS

MODEL NO.	GF1007MX (RoHS)					
1	NOMINAL SIZE	100 mm	4	inch		
2	IMPEDANCE	8 Ω ± 15%	at. 500 Hz	1 V		
3	RESONANCE FO	250 Hz ± 50 Hz	FO Hz	1 V		
4	S.P. LEVEL	96 dB/w ± 2 dB	1 W 50 cm average at			
5	FREQ. RESPONSE	Fo Hz ~ 15K Hz				MAX 10 dB
6	INPUT POWER	Nominal Input 10 W	Handling Capacity 20 W			
7	OPERATION	Must be normal at program source 10 W				
8	BUZZ, RATTLE, ETC.	Must be normal at Sine Wave 6.3 V				
9	MAGNET	70 x 32 x 10 mm				
10	FLUX DENSITY	Gauss ± 10%	total flux max well within			
11	TOTAL WEIGHT		gr	oz		
12	LOAD TEST	After test meets Item 7 and 8	White noise 10 W 24 Hours			
13	DISTORTION					
14	HEAT TEST	After test meets Item 7 and 8	60 ± 2° C 20-50 % R.H. 24 Hours			
15	HUMIDITY TEST	After test meet Item 7 and 8	40 ± 2° C 90-95 % R.H. 24 Hours			

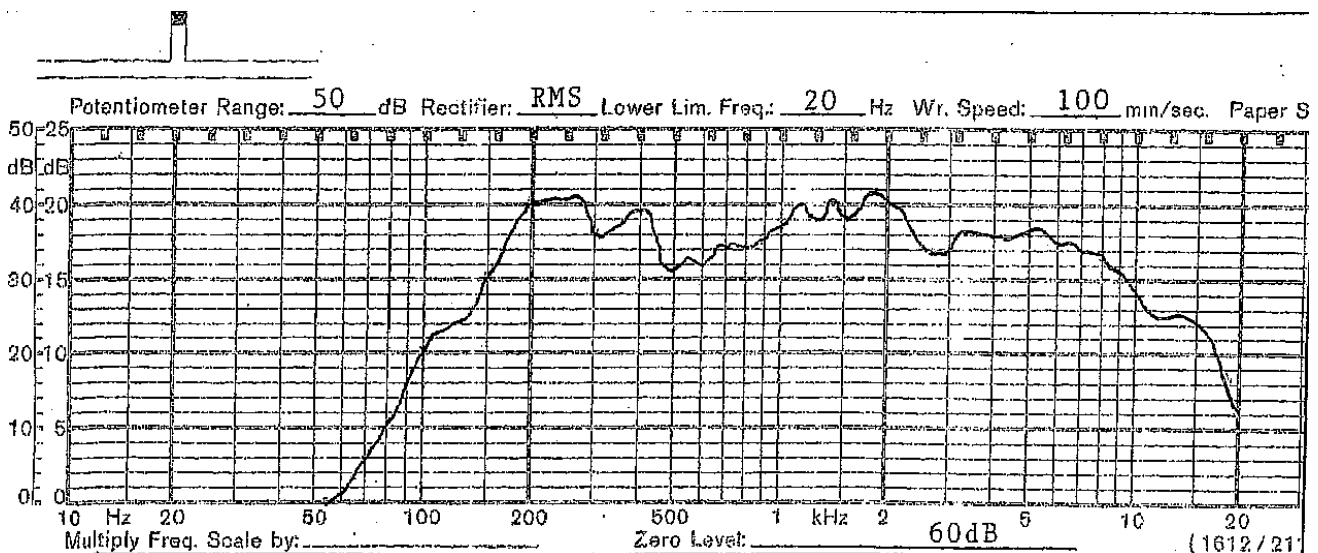

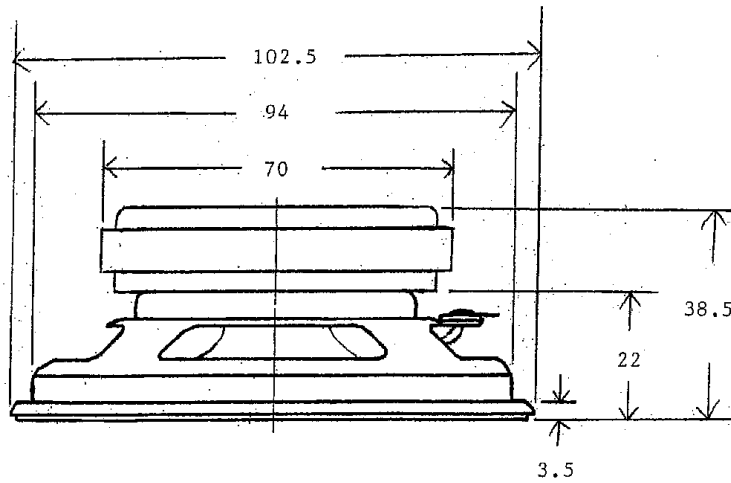
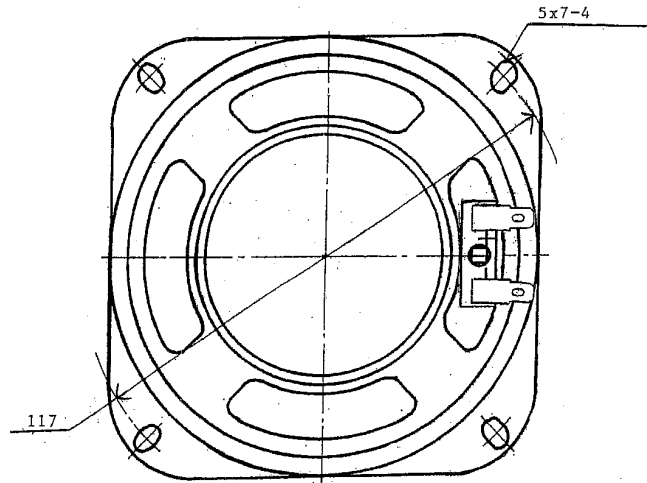

TOLERANCE: ± 0.5 MM

MODEL NO. GF1007MX

APPROVED	CHECKED	DRAWING