

仕様
SPECIFICATION

1. 絶縁抵抗 : DC100Vにて100MΩ以上
INSULATION RESISTANCE: 100MΩ MIN. AT DC 100V.
2. 耐電圧 : AC500V1分間
DIELECTRIC STRENGTH: AC500V FOR ONE MINUTE.
3. 接触抵抗 : 50mΩ以下
CONTACT RESISTANCE: 50mΩ MAX.

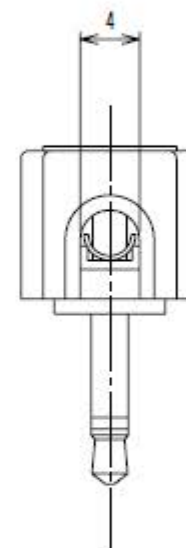
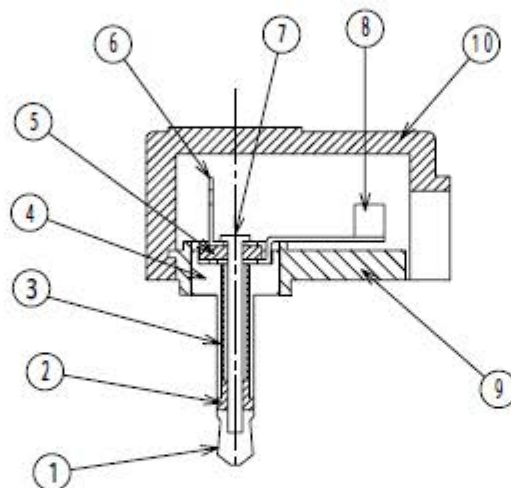
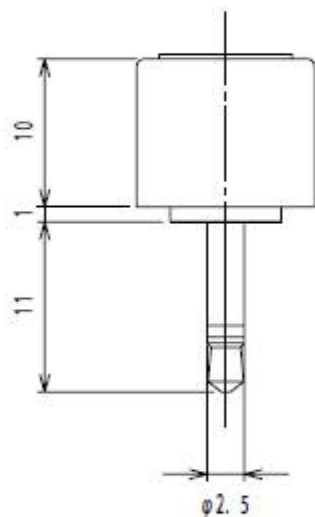

10	CAP	キャップ	PP												
9	BASE	ベース	PC		1										
8	SLEEVE TERMINAL	スリーブプラグ	STEEL 鉄		1	NI									
7	TIP PIN	シャフト	STEEL 鉄		1	NI									
6	TIP TERMINAL	チッププラグ	BRASS 黄銅		1	NI									
5	INSULATOR C	絶縁ワッシャー	PF フェノール		1										
4	SLEEVE METAL	スリーブメタル	BRASS 黄銅		1	NI									
3	INSULATOR B	絶縁チューブ	PVC		1										
2	INSULATOR A	絶縁カラー	EBONITE エポナイト		1										
1	TIP	チップ	BRASS 黄銅		1	NI									
LET	PART NAME		MATERIAL		QTY	FINISH									
								TOLERANCE	SCALE	DATE	DESING	DRAW	INSPE	APRO	
									2/1	8/8/20	M. K	N. I			
										MODEL	QTY	PART NAME			
										型式		品名	φ2.5モノラルプラグ No. MP-022L		
										MATERIAL		DRAW. NO			
										材質		図番	MP022L		
										FINISH					
										処理	SHOGYO INTERNATIONAL CORPORATION				