

SCHEMATIC	
MODEL NO	C

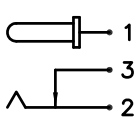
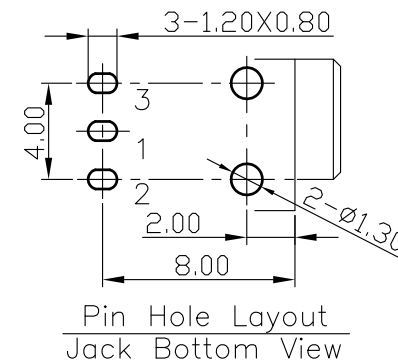
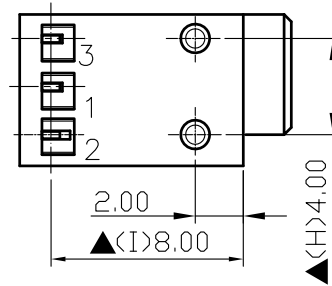
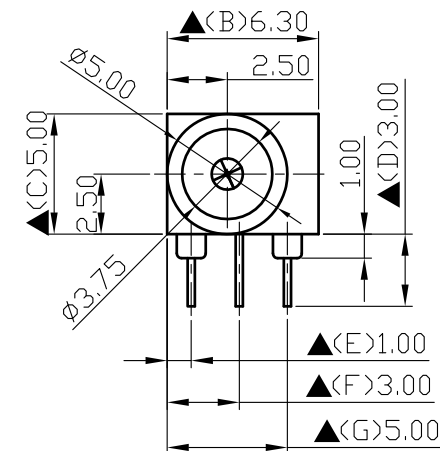
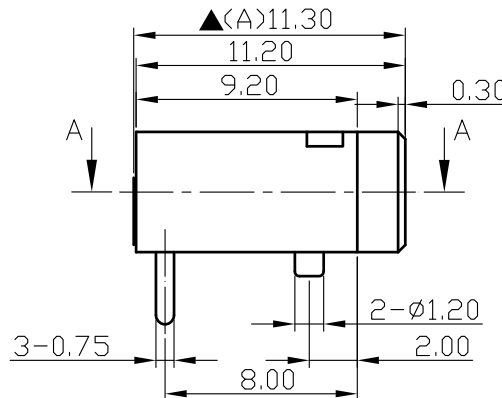
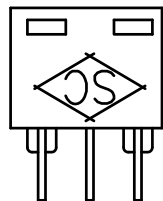
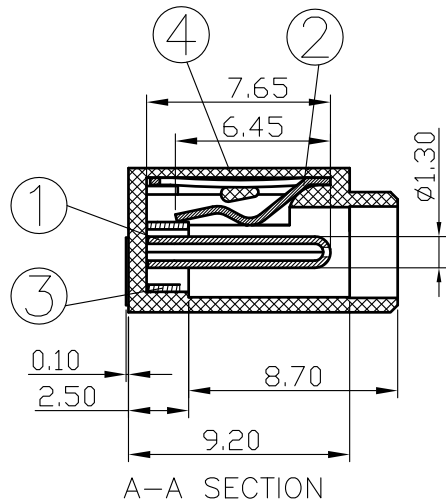
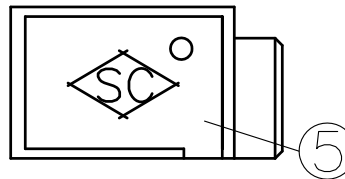

5.	Cover	PBT+30%	1	Black Color
4.	Housing	PBT+30%	1	Black Color
3.	Pin Terminal	0.3T Brass	1	Silver Plated
2.	Sleeve Spring	0.3T Beryllium	1	Silver Plated
1.	Pin(1.3φ)	0.3T Brass	1	Silver Plated
NO.	Description	Material	Q'TY	Finish

# SHOGYO

DATE	DWN	CHKD	APVD	MANAGER
09.23.2021	王平華			

For Redference  
僅供參考

RoHS&SVHC  
Compliant

PART NAME : DC POWER JACK

PART NUMBER: SCD411ACS000B00G

VERSION:11.0

TOLERANCE :±0.3mm UNLESS OTHERWISE SPECIFIED

UNIT:mm 

SCALE:1/1

SPECIFICATIONS:

Contact Resistance : 30mΩ max  
Current Rating : Max 5A , 24V DC  
Insulation Resistance : 100MΩ min. at DC 500V  
Remark: ▲: The Most Important Dimension