





- ① Series No.
- ② Bushing Code: See next page for details.
- ③ Bushing Plating: “0”: No Plating (Fully Plastic Bushing), “N”: Nickel, “S”: Silver, “G”: Gold Flash, “8”: With Transparent Cover (For SCJ313 Only)
- ④ Schematic Code: Please see individual specification drawings for options.
- ⑤ Terminal Plating: “S”: Silver (Standard); “T”: Tin, “G”: Gold Flash
- ⑥ Nut Option: “0”: Without Nut, “1”: With Round Nut (M6 x P0.5), “2”: With Hexagonal Nut (M6 x P0.5), “3” With Round Nut (M8 x P0.75), “5”: With Hexagonal Nut (M8 x P0.75)
- ⑦ Plastic Housing Color: “B”: Black (Standard). Virtually all colors are available. Inquire within for special requests.
- ⑧ Special Options: “00”: No Special Option
 - (i) For SCJ325/326/327:
 - “01”: Two Plastic Posts (0.5mm in height)
 - “02”: Two Plastic Posts (1.0mm in height)
 - “03”: One Plastic Post (0.5mm in height)
 - (ii) For SCJ349/350/360/361/362/363:
 - “01”: Kinked Solder Tail
 - “02”: Straight Solder Tail
 - (iii) For SCJ339/340:
 - “NP”: Without Back Plastic Hook
 - (iv) For SCJ351/352:
 - “NS”: With Metal Shell
 - (v) For SCJ364:
 - “N0”: With Metal Shell
- ⑨ RoHS Compliance: “G”



Bushing Figure	Ordering Code	Bushing Construction			Available Shogyo Series Numbers
		Material	Thread	Metal Ring	
	M0	Metal	X	X	SCJ324, 328, 354, 356, 357, 358, 368, 379, 391, 394
	M1	Metal	M6 X P0.5	X	SCJ310, 311, 312, 314, 324, 328, 354, 356, 357, 358, 368, 379, 380, 392
	M2	Metal bushing with plastic bushing cap	X	X	SCJ324, 356, 367
	M5	Metal bushing with plastic bushing cap	X	X	SCJ351, 352, 356, 359
	M7	Metal bushing with plastic bushing cap	X	X	SCJ391, 394
	P0	Plastic	X	X	SCJ 300, 301, 303, 304, 305, 306, 313, 315, 316, 320, 321, 322, 325, 326, 327, 330, 332, 333, 334, 336, 337, 338, 339, 340, 342, 344, 345, 348, 349, 350, 351, 352, 355, 360, 361, 362, 363, 364, 368, 370, 371, 372, 373, 375, 379, 385, 397, 3007, 3008
	P1	Plastic	M8 X P0.75	X	SCJ330, 332, 364



Bushing Figure	Ordering Code	Bushing Construction			Available Shogyo Series Numbers
		Material	Thread	Metal Ring	
	R0	Plastic	X	With Metal Ring 1) O.D.: Ø5.0mm ~Ø5.5mm 2) Position: Inside Bushing	SCJ303, 313, 320, 338, 339, 340, 348, 355, 368, 374, 375, 379, 380
	R1	Plastic	X	With Metal Ring 1) O.D.: Ø6.0mm 2) Position: Outside Bushing	SCJ355, 368, 379
	R4	Plastic	M6 X P0.5	With Metal Ring 1) O.D.: Ø5.5mm 2) Position: Outside Bushing	SCJ368, 379
	R5	Metal	X	With Metal Ring 1) O.D.: Ø6.0mm 2) Position: Outside Bushing	SCJ374
	R6	Metal	X	X	SCJ301
	R7	Plastic	X	With Metal Ring Inside Bushing	SCJ317, 376

Nut

Unit: m/m

Fig. 1

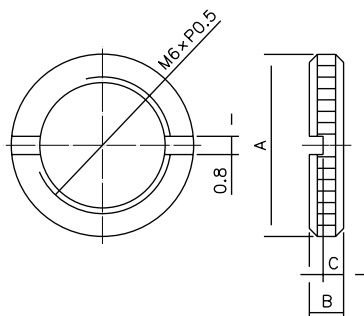

Fig. 2

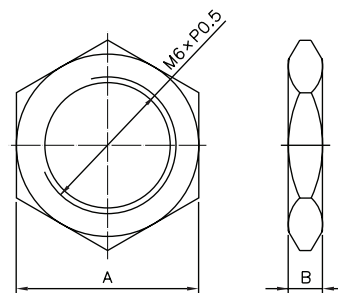
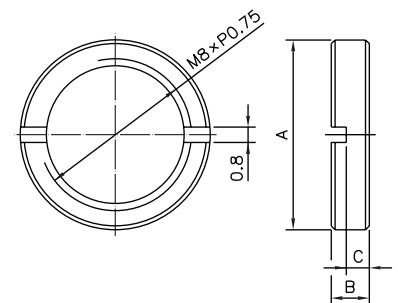

Fig. 3





Ordering Code	Fig	Shape	Description			Dimension		
			Thread	Material	Plating	Dim. A	Dim. B	Dim. C
1	Fig. 1	Round	M6 X P0.5	Brass	Nickel	Ø8.0	1.5	0.9
2	Fig. 2	Hexagonal	M6 X P0.5	Brass	Nickel	8.0	1.5	--
3	Fig. 3	Round	M8 X P0.75	Brass	Nickel	Ø10.0	2.0	1.2