

PCB MOUNTING LAYOUT

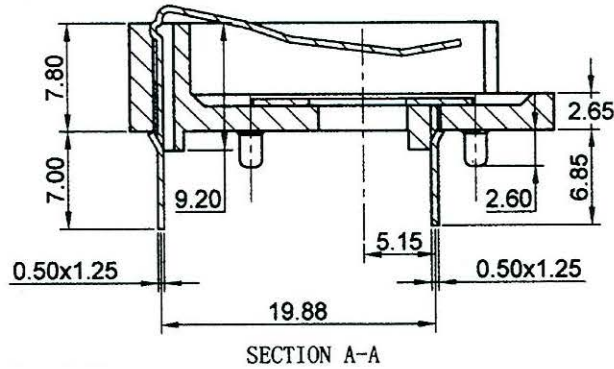

SPECIFICATION

- (1) ITEM NO. : CH032-2477LF
- (2) HOUSING MATERIAL: PBT UL94V0, BLACK COLOR
- (3) CONTACT MATERIAL: 0.5MM SPRING STEEL NICKEL PLATED
- (4) CURRENT RATING : 0.5A (AC/DC)
- (5) VOLTAGE RATING : 500V (AC/DC)
- (6) CONTACT RESISTANCE: 30 MILLIOHMS
- (7) INSULATION RESISTANCE: 1000 MEGAOHMS
- (8) TEMPERATURE RANGE: -55° C TO +85° C
- (9) HUMIDITY: 40° C AND 90-95% RH FOR 96 HOURS
- (10) RoHS COMPLIANT

3				
2				
1				
NO.	MODIFICATION	DATE	SCALE	2:1
General Tolerances			UNIT	MM
0 ~ >3	± 0.10	30 ~ >120	MAT'L	SEE SPEC.
3 ~ >6	± 0.10	120 ~ >400	DATE	NOV. 18. 2013
6 ~ >30	± 0.20	Angle: ± 3°		

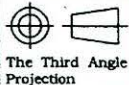

SHOGYO INTERNATIONAL CORP.

#CH032-2477LF

COIN CELL HOLDER