

PCB LAYOUT

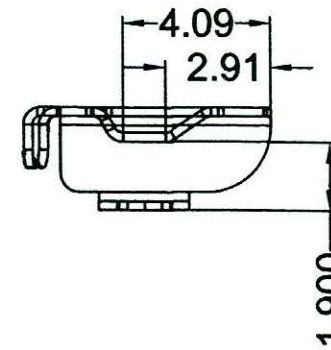
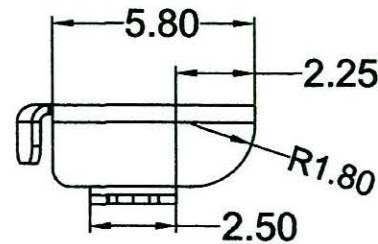
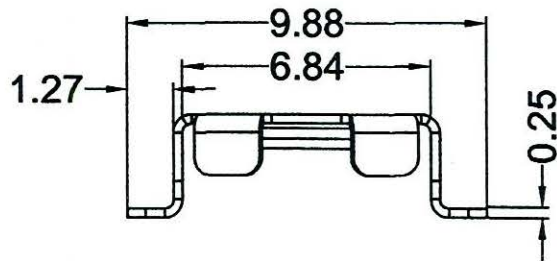

NOTES:

- 0.25mm PHOSPHOR BRONZE 1/2H, NICKEL PLATED 4u"~6u"
- TEMPERATURE RANGE: -40°C TO +270°C
- *VIBRATION TEST: 10-50-10 HZ SWEEPED IN 60 SECONDS
X,Y,Z DIRECTION: 1 HOUR EACH DIRECTION
- *RESULT: NO DISLODGEEMENT OF THE CELL OR DAMAGE
NO DISCONTINUITY OVER 10 MICRO-SECONDS
- *SHOCK TEST: HALF SINE WAVE ACCELERATION 150G. 6 MILLI-SECONDS
3 SHOCK PULSES EACH DIRECTION PER AXIS, TOTAL OF 18 PULSES
- *RESULT: NO EVIDENCE OF PHYSICAL DAMAGE
- *DROP TEST: DROPPED FROM 1M HIGH TO CONCRETE FLOOR
- *RESULT: NO EVIDENCE OF PHYSICAL DAMAGE
- ROHS 2 COMPLIANT

2				
	changed the Product number from ML621 to BC-6801	AUG/05 /2016		
NO.	MODIFICATION	DATE	SCALE	1:1
General Tolerances				
0 ~ >3	± 0.10	30 ~ >120	± 0.30	
3 ~ >6	± 0.10	120 ~ >400	± 0.50	
6 ~ >30	± 0.20	Angle: ± 3°		
		The Third Angle Projection	UNIT	MM
			MAT'L	SEE SPEC.
			DATE	AUG. 05. 2016

SHOGYO INTERNATIONAL CORP.

#BC-6801

BATTERY CLIP