

# SHOGYO INTERNATIONAL CORP.

www.shogyo.com

## SPEAKER SPECIFICATIONS

MODEL NO.		GC0148MGX (RoHS)				
1	NOMINAL SIZE	14.8 mm	inch			
2	IMPEDANCE	8 $\Omega$ $\pm$ 15%	at. 1K Hz	0.894 V		
3	RESONANCE FO	450 Hz $\pm$ 90 Hz	FO Hz	0.894 V		
4	S.P.L. LEVEL	82 dB/w $\pm$ 3 dB	0.1 W 10 cm average at			
5	FREQ. RESPONSE	Fo Hz ~ 20K Hz				800, 1K, 1.2K, 1.6K Hz
6	INPUT POWER	Nominal Input 0.1 W	Handling Capacity 0.2 W			
7	OPERATION	Must be normal at program source 0.1 W				
8	BUZZ, RATTLE, ETC.	Must be normal at Sine Wave 0.894 V				
9	MAGNET	6.5 x 1.5 mm				
10	FLUX DENSITY	Gauss $\pm$ 10%	total flux max well within			
11	DISTORTION					
12	LOAD TEST	After test meet Item 7 and 8	White noise	0.1 W	24 Hours	
13	OPERATION TEMP.					
14	HEAT TEST	After test meet Item 7 and 8	60 $\pm$ 2° C	20-50 % R.H.	24 Hours	
15	HUMIDITY TEST	After test meet Item 7 and 8	40 $\pm$ 2° C	90-95 % R.H.	24 Hours	

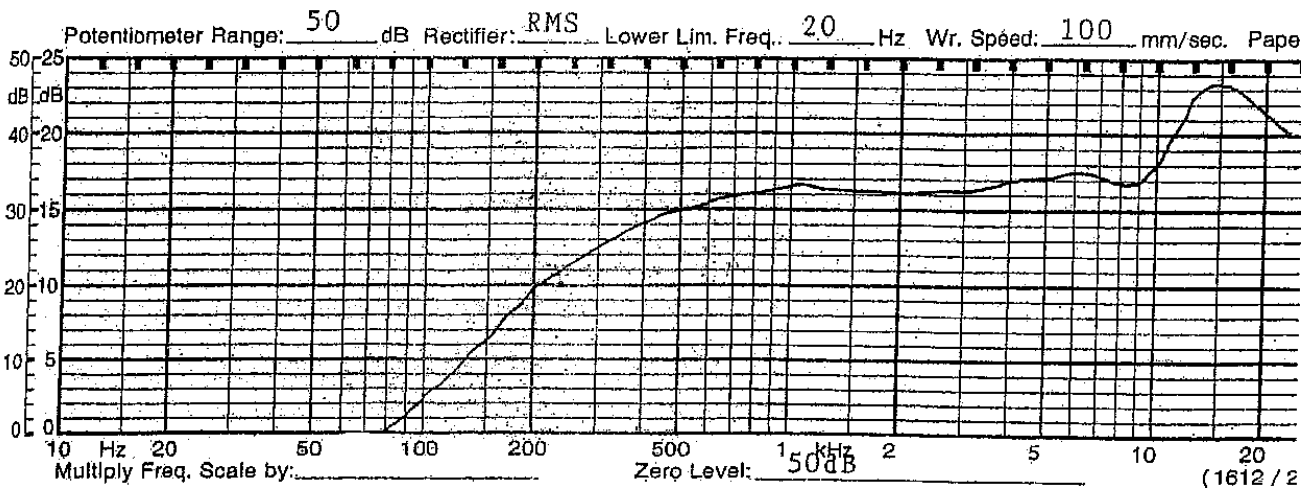

RED POINT  
(SHOW THE POSITIVE)

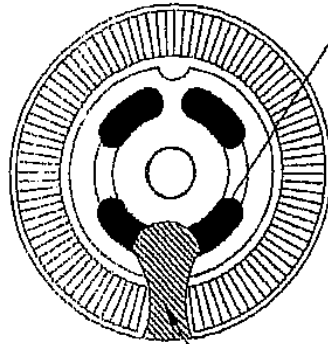

WHITE GLUE

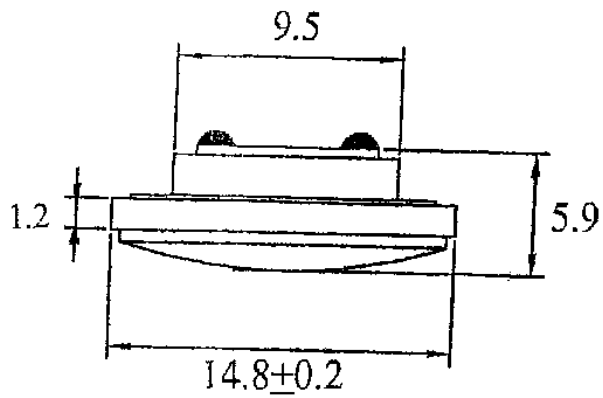

TOLERANCE:  $\pm 0.2$  MM

MODEL NO. GC0148MGX

APPROVED	CHECKED	DRAWING