

SHOGYO INTERNATIONAL CORP.

www.shogyo.com

SPEAKER SPECIFICATIONS

MODEL NO.	GC0154MG-1X (RoHS)		
1	NOMINAL SIZE	15 mm	CONE MATERIAL: MYLAR
2	IMPEDANCE	32 $\Omega \pm 15\%$	at. 1K Hz 0.178 V
3	RESONANCE FO	300 Hz \pm 60 Hz	FO Hz 0.178 V
4	S.P. LEVEL	116 dB/w \pm 3 dB	Test with IEC-318 at 0.001w / 1K Hz
5	FREQ. RESPONSE	Fo Hz ~ 20K Hz	
6	INPUT POWER	Nominal Input 0.005 W	Max Output 0.01 W
7	OPERATION	Must be normal at program source 0.005 W	
8	BUZZ, RATTLE, ETC.	Must be normal at Sine Wave 0.4 V	
9	MAGNET	NdFeB 6.5 x 2 x 1.5 mm	
10	FLUX DENSITY	Gauss \pm 10% total flux max well within	
11	TOTAL WEIGHT	gr	oz
12	LOAD TEST	After test meets Item 7 and 8	White noise 0.005 W 24 Hours at 25°C (room temp.)
13	DISTORTION		
14	HEAT TEST	After test meets Item 7 and 8	50 \pm 2° C 20-50 % R.H. 24 Hours
15	HUMIDITY TEST	After test meet Item 7 and 8	40 \pm 2° C 90-95 % R.H. 24 Hours

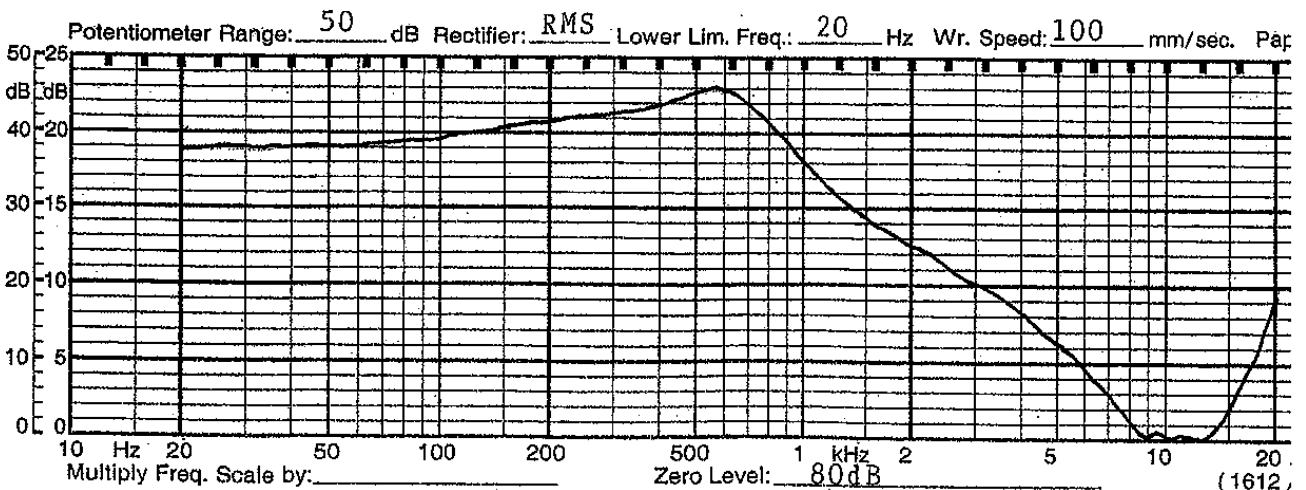

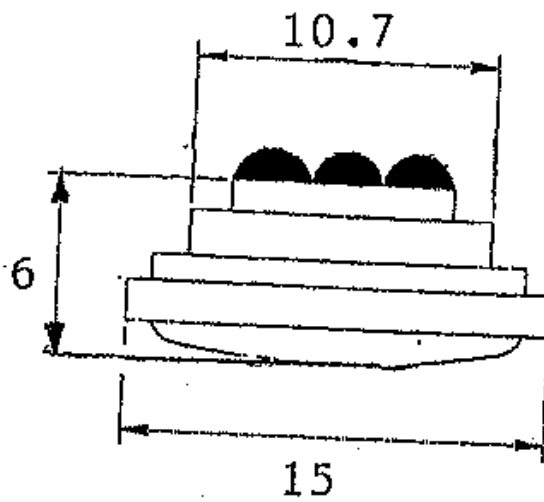
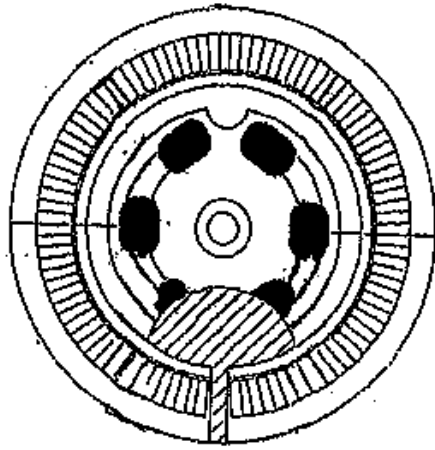

TOLERANCE: ± 0.3 MM

MODEL NO. GC0154MG-1X

APPROVED	CHECKED	DRAWING