

SHOGYO INTERNATIONAL CORP.

www.shogyo.com

SPEAKER SPECIFICATIONS

MODEL NO.	GC0501MPX (RoHS)				
1	NOMINAL SIZE	50 mm	2	inch	
2	IMPEDANCE	8 Ω \pm 15%	at.	800 Hz	1 V
3	RESONANCE FO	550 Hz \pm 110 Hz	FO	Hz	1 V
4	S.P.L. LEVEL	80 dB/w \pm 3 dB	0.2 W 50 cm average at 900, 1.2K, 1.5K, 1.8K Hz		
5	FREQ. RESPONSE	Fo Hz ~ 13K Hz			
6	INPUT POWER	Nominal Input 0.2 W	Handling Capacity 0.5 W		
7	OPERATION	Must be normal at program source 0.2 W			
8	BUZZ, RATTLE, ETC.	Must be normal at Sine Wave 1.26 V			
9	MAGNET	12.5 x 1.5 mm			
10	FLUX DENSITY	Gauss \pm 10% total flux max well within			
11	DISTORTION				
12	LOAD TEST	After test meet Item 7 and 8	White noise 0.2 W 24 Hours		
13	OPERATION TEMP.				
14	HEAT TEST	After test meet Item 7 and 8	60 \pm 2° C 20-50 % R.H. 24 Hours		
15	HUMIDITY TEST	After test meet Item 7 and 8	40 \pm 2° C 90-95 % R.H. 24 Hours		

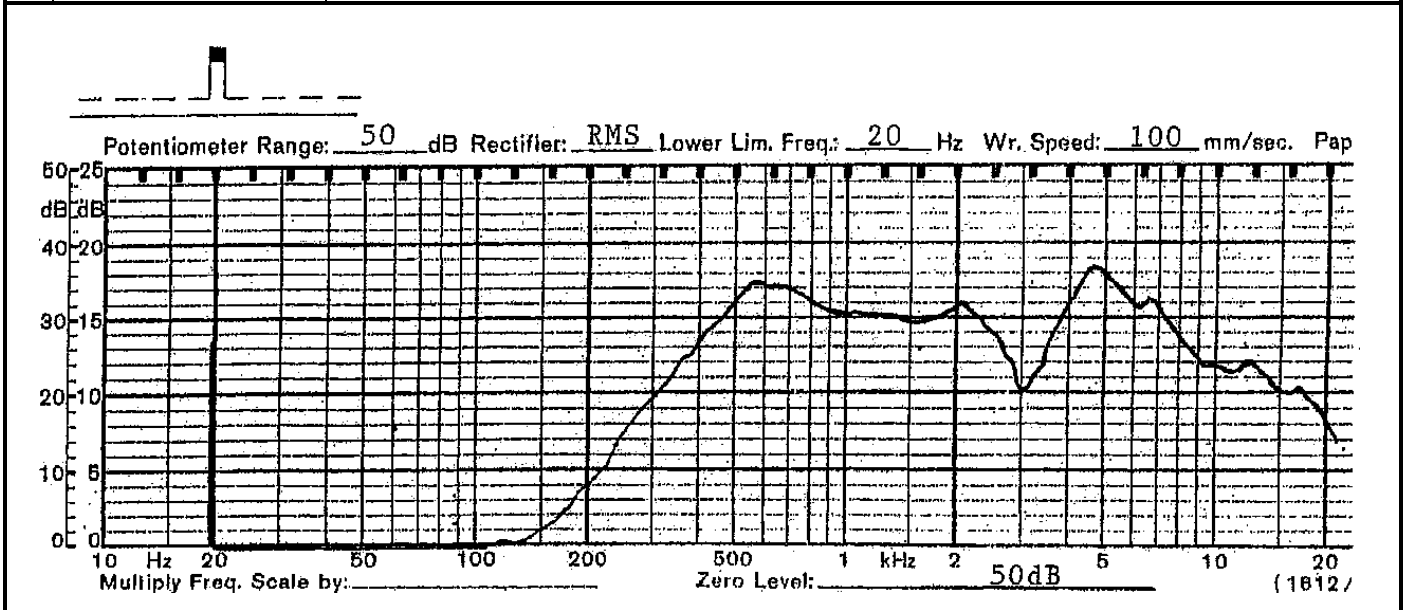

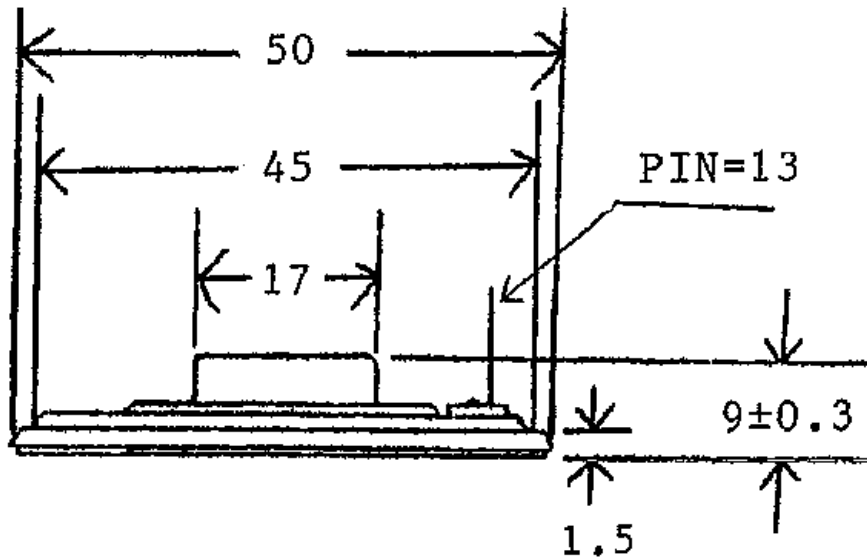
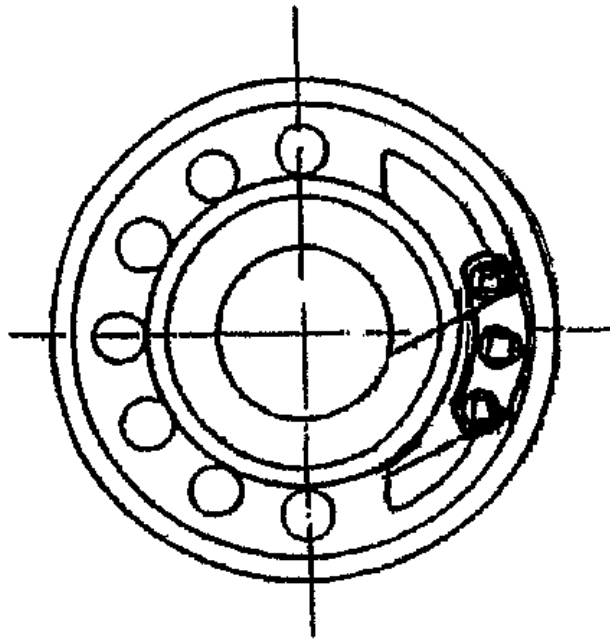

TOLERANCE: $\pm 0.8\text{MM}$

MODEL NO. GC0501MPX		
APPROVED	CHECKED	DRAWING