

# SHOGYO INTERNATIONAL CORP.

www.shogyo.com

## SPEAKER SPECIFICATIONS

<b>MODEL NO.</b>	<b>GC0571HL-1X (RoHS)</b>					
<b>1</b>	<b>NOMINAL SIZE</b>	<b>57 mm</b>	<b>inch</b>			
<b>2</b>	<b>IMPEDANCE</b>	<b>8 Ω ± 15%</b>	<b>at. 1K Hz</b>		<b>1 V</b>	
<b>3</b>	<b>RESONANCE FO</b>	<b>170 Hz ± 34 Hz</b>	<b>FO Hz</b>		<b>1 V</b>	
<b>4</b>	<b>S.P. LEVEL</b>	<b>91 dB/w ± 3 dB</b>	<b>1 W 50 cm average at</b>			
<b>5</b>	<b>FREQ. RESPONSE</b>	<b>Fo Hz ~ 20K Hz</b>	<b>MAX 10 dB</b>	<b>250, 300, 400, 500 Hz</b>		
<b>6</b>	<b>INPUT POWER</b>	Nominal Input <b>1 W</b>		Handling Capacity <b>2 W</b>		
<b>7</b>	<b>OPERATION</b>	Must be normal at program source <b>1 W</b>				
<b>8</b>	<b>BUZZ, RATTLE, ETC.</b>	Must be normal at Sine Wave <b>2.83 V</b>				
<b>9</b>	<b>MAGNET</b>	<b>12.5 x 3.0 mm</b>				
<b>10</b>	<b>FLUX DENSITY</b>	<b>Gauss ± 10%</b>	<b>total flux max well within</b>			
<b>11</b>	<b>TOTAL WEIGHT</b>	gr		oz		
<b>12</b>	<b>LOAD TEST</b>	After test meets Item 7 and 8	White noise <b>1 W 24 Hours</b>			
<b>13</b>	<b>DISTORTION</b>					
<b>14</b>	<b>HEAT TEST</b>	After test meets Item 7 and 8	<b>65 ± 2° C 20-50 % R.H. 24 Hours</b>			
<b>15</b>	<b>HUMIDITY TEST</b>	After test meet Item 7 and 8	<b>40 ± 2° C 90-95 % R.H. 24 Hours</b>			

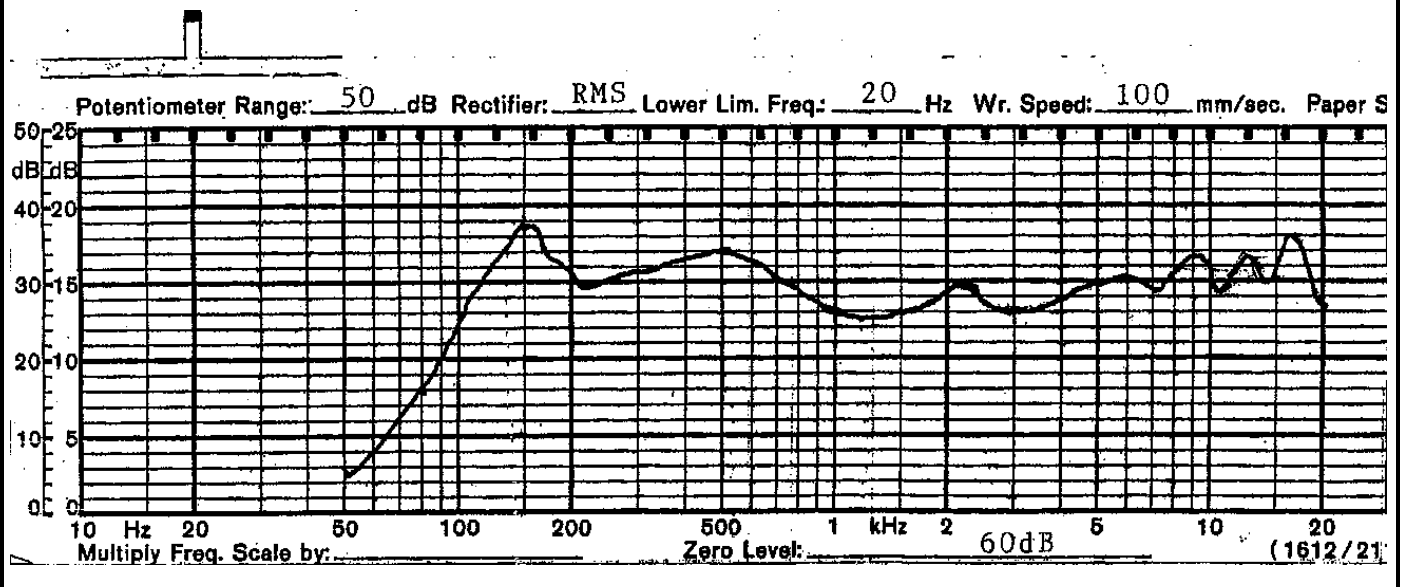

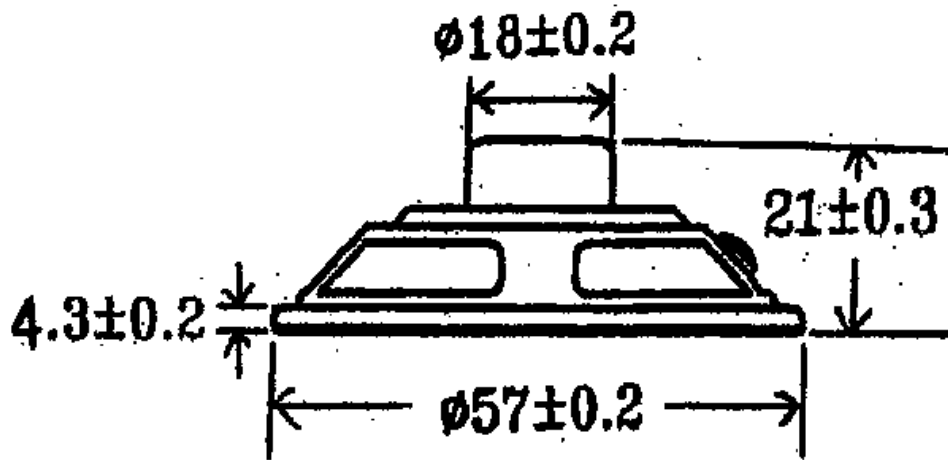
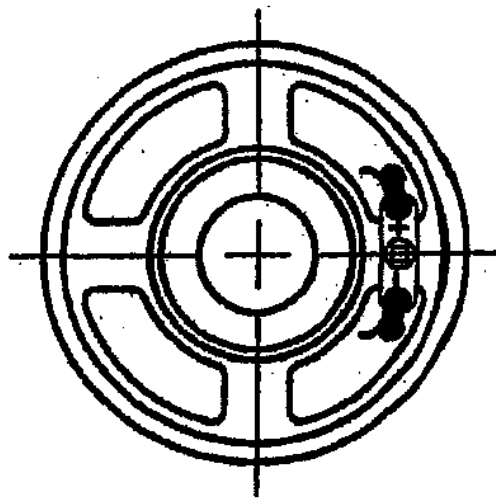

MODEL NO. GC0571HL-1X

APPROVED	CHECKED	DRAWING