

SHOGYO INTERNATIONAL CORP.

www.shogyo.com

SPEAKER SPECIFICATIONS

MODEL NO.	GC0571MX (RoHS)				
1	NOMINAL SIZE	57 mm	2-1/4	inch	
2	IMPEDANCE	8 Ω ± 15%	at. 800 Hz	1 V	
3	RESONANCE FO	530 Hz ± 100 Hz	FO Hz	1 V	
4	S.P. LEVEL	89 dB/w ± 3 dB	0.2 W 50 cm average at 1K, 1.4K, 1.7K, 2K Hz		
5	FREQ. RESPONSE	Fo Hz ~ 20K Hz			
6	INPUT POWER	Nominal Input 0.2 W	Handling Capacity 0.5 W		
7	OPERATION	Must be normal at program source 0.2 W			
8	BUZZ, RATTLE, ETC.	Must be normal at Sine Wave 1.3 V			
9	MAGNET	12.5 x 1.5 mm			
10	FLUX DENSITY	Gauss ± 10%	total flux max well within		
11	TOTAL WEIGHT		gr	oz	
12	LOAD TEST	After test meets Item 7 and 8	White noise 0.2 W 24 Hours		
13	DISTORTION				
14	HEAT TEST	After test meets Item 7 and 8	60 ± 2° C 20-50 % R.H. 24 Hours		
15	HUMIDITY TEST	After test meet Item 7 and 8	40 ± 2° C 90-95 % R.H. 24 Hours		

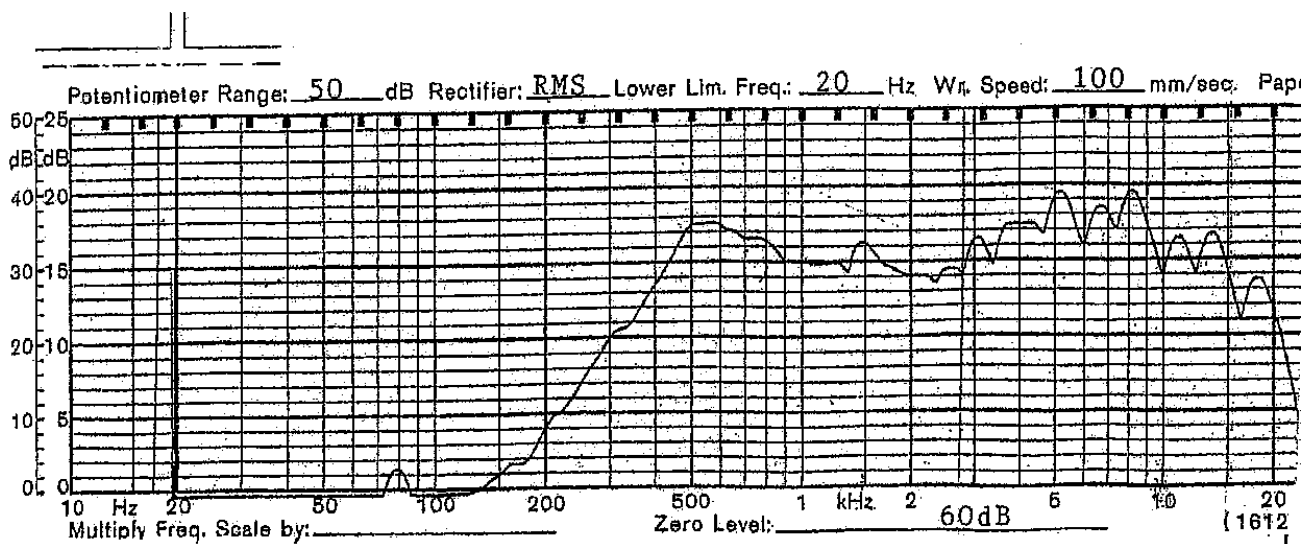

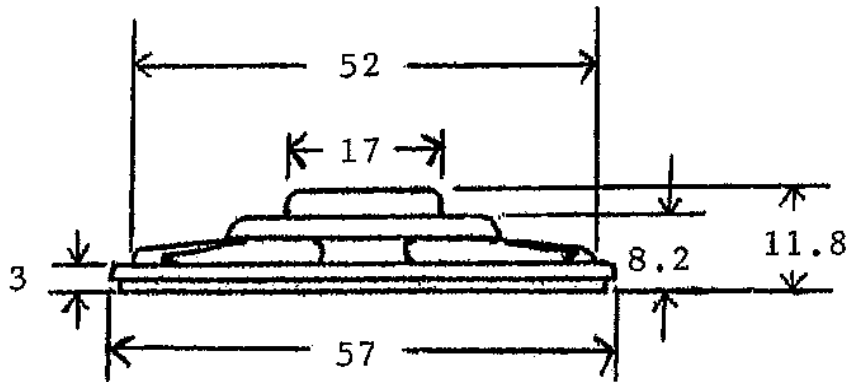
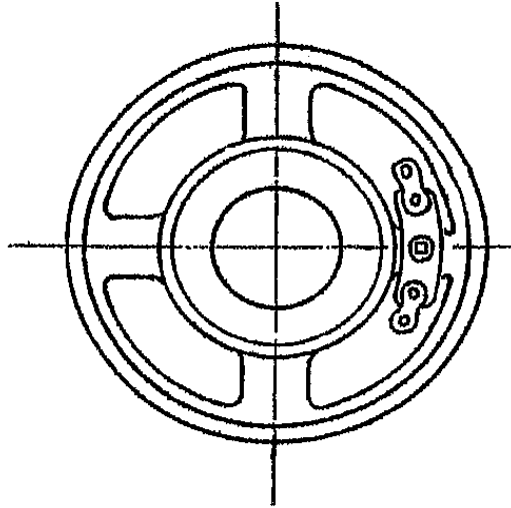

TOLERANCE: ± 0.8 MM

MODEL NO. GC0571MX

APPROVED	CHECKED	DRAWING