

SPECIFICATIONS SHEET

PRODUCT TYPE : EXTERNAL DRIVE PIEZO TRANSDUCER
PRODUCT SERIES : DB-E1198
DESCRIPTION : PZ TRANSDUCER 12V SMD PPS SP
1) TAPE & REEL PACKING 2) RoHS
COLOR : GREY

ELECTRICAL SPECIFICATIONS

| | |
|------------------------------|--|
| MODEL NO. | <i>119PZ15500LFR - MP</i> |
| SOUND PRESSURE LEVEL | 85 dBA min. (12.0 V p-p Square Wave , 10 cm , 5000 Hz) |
| CAPACITANCE | 12000 pF ± 30 % at 120 Hz |
| * MAX. INPUT VOLTAGE | 40 V p-p |
| OPERATING TEMPERATURE | -20 ~ +70 °C |
| TERMINAL | SMD |
| HOUSING MATERIAL | PPS |
| * WEIGHT | 2.0 g |

DIMENSIONS

UNIT : mm

TOP VIEW

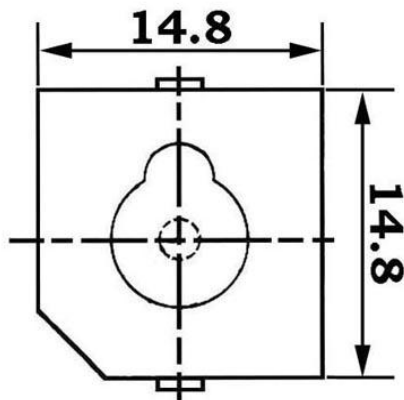

SIDE VIEW

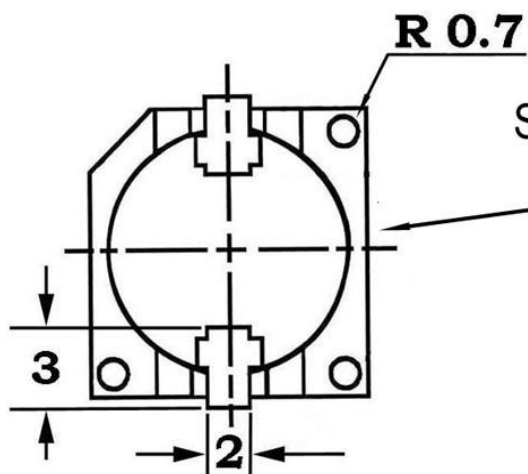
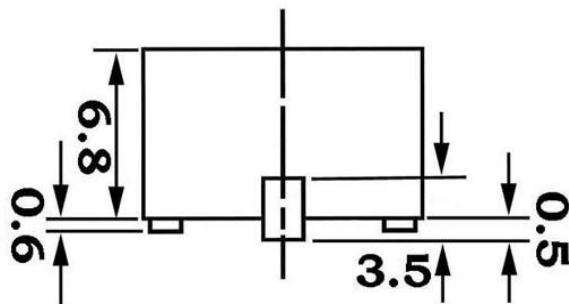

Silk Screen Marking

" LF XX "

Date Code Marking

" 5 / K "

Year | Month
 5 = 2005 | K = Nov.

BOTTOM VIEW

| | | |
|----------|--------|------|
| Modify : | Date : | By : |
| | | |
| | | |

Approved By :
Date : 22-Nov.-2005

Prepared By :
Date : 22-Nov.-2005