

SPECIFICATIONS SHEET

PRODUCT TYPE : EXTERNAL DRIVE PIEZO TRANSDUCER

PRODUCT SERIES : DB-E1208

DESCRIPTION : PZ TRANSDUCER 3V ABS 90mmLL RoHS

COLOR : BLACK

ELECTRICAL SPECIFICATIONS

MODEL NO.	120PZ17200LFLA
SOUND PRESSURE LEVEL	75.0 dBA Min. (3.0 Vrms Sine Wave , 10.0 cm , 2000.0 Hz)
CAPACITANCE	23000.0 pF ± 30.0 % at 120.0 Hz
* MAX. INPUT VOLTAGE	30.0 Vrms
OPERATING TEMPERATURE	- 20.0 ~ + 70.0 °C
STORAGE TEMPERATURE	- 30.0 ~ + 80.0 °C
TERMINAL	LEADWIRE (UL1571 , AWG#30)
HOUSING MATERIAL	ABS
* WEIGHT	1.0 g

DIMENSIONS

UNIT : mm

Tolerance : ± 0.5 mm

SIDE VIEW

TOP VIEW

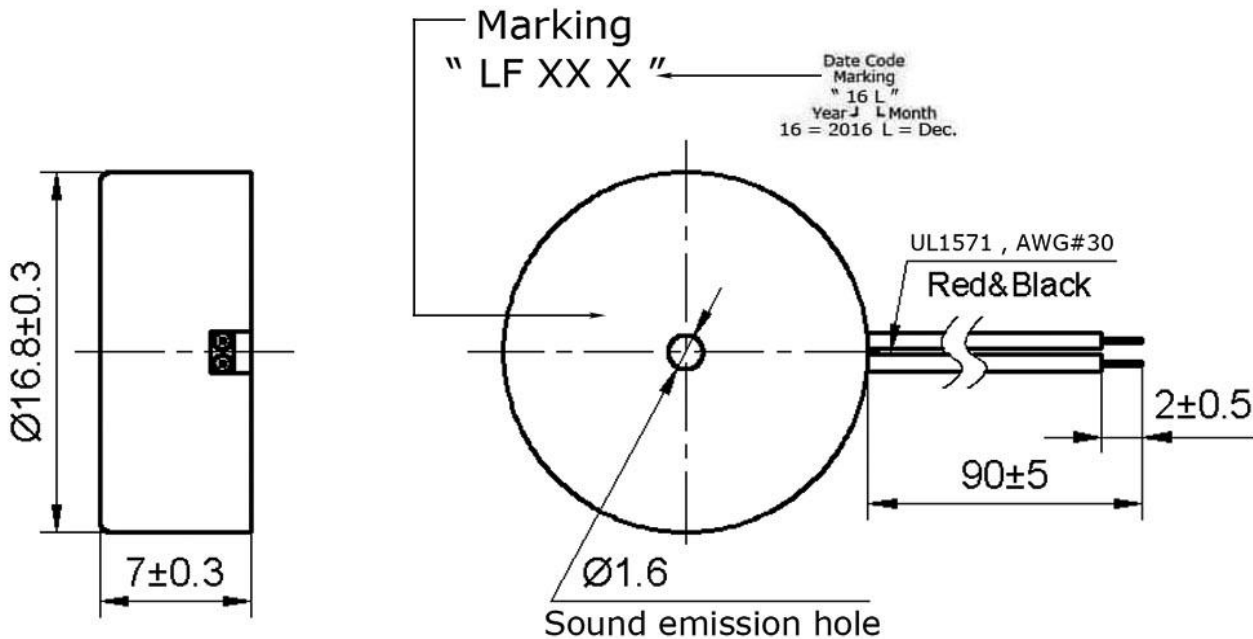

Modify :	Date :	By :
1) Strip wire 1.7 ± 0.2 mm change to 2 ± 0.5 mm. 2) Capacitance 23000 pF ± 30 % at 1 KHz change to 120Hz. 3) Max. Input Volatage 30 Vp-p changwe to 3 Vrms. 4) Add Storage Temp.	21-Dec.-2016	Chris

Approved By :
Date : 21-Dec.-2016

Prepared By :
Date : 21-Dec.-2016