

SPECIFICATIONS SHEET

PRODUCT TYPE : EXTERNAL DRIVE PIEZO TRANSDUCER

PRODUCT SERIES : DB-EI888

DESCRIPTION : PZ TRANSDUCER 12V SMD PA46 RoHS SP
DATA CODE " LF YEAR MONTH DATE "

COLOR : BLACK

ELECTRICAL SPECIFICATIONS

MODEL NO.	188PZ22400LF-002
SOUND PRESSURE LEVEL	90.0 dBA Min. (12.0 V p-p Square Wave , 10.0 cm , 4000 Hz)
CAPACITANCE	19000.0 pF ± 30 % at 120.0 Hz
* OPERATING VOLTAGE	1.0 ~ 30.0 V p-p
OPERATING TEMPERATURE	- 20.0 ~ + 70.0 °C
STORAGE TEMPERATURE	- 30.0 ~ + 80.0 °C
TERMINAL	SMD
HOUSING MATERIAL	PA46
* WEIGHT	2.8 g

DIMENSIONS

UNIT : mm

Tolerance : ± 0.5 mm

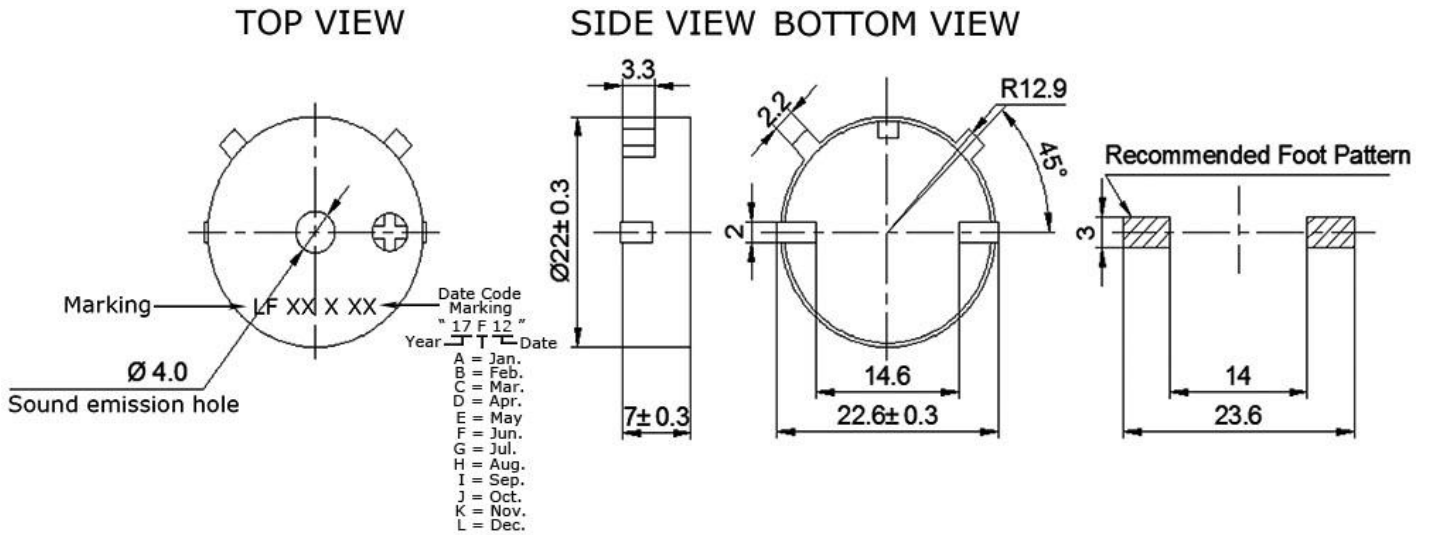

Modify :	Date :	By :
1) Modify Date Code " LF YEAR / WEEK " change to " LF YEAR MONTH DATE "	12-Jun-17	Nelson
2) Modify Mechanical Draw.		
3) Max. Input Voltage 30 Vp-p change to Operating Voltage 1 ~ 30 Vp-p.		
4) Ø 22.1 ± 0.3 change to Ø 22 ± 0.3 mm.		

Approved By :
 Date : 12 Jun 2017

Prepared By :
 Date : 12 Jun 2017