

SHOGYO INTERNATIONAL CORP.

www.shogyo.com

SPEAKER SPECIFICATIONS

MODEL NO.	GF0501MHX (RoHS)				
1	NOMINAL SIZE	50 mm	2 inch		
2	IMPEDANCE	8 Ω ± 15%	at. 800 Hz	1 V	
3	RESONANCE FO	500 Hz ± 100 Hz	FO Hz	1 V	
4	S.P. LEVEL	86 dB/w ± 3 dB	1 W 50 cm average at 1K, 1.3K, 1.7K, 2K Hz		
5	FREQ. RESPONSE	Fo Hz ~ 11K Hz			
6	INPUT POWER	Nominal Input 1 W	Handling Capacity 2 W		
7	OPERATION	Must be normal at program source 1 W			
8	BUZZ, RATTLE, ETC.	Must be normal at Sine Wave 2.83 V			
9	MAGNET	32 x 18 x 6 mm			
10	FLUX DENSITY	Gauss ± 10%	total flux max well within		
11	TOTAL WEIGHT	gr	oz		
12	LOAD TEST	After test meets Item 7 and 8	White noise 1 W 24 Hours		
13	DISTORTION				
14	HEAT TEST	After test meets Item 7 and 8	60 ± 2° C 20-50 % R.H. 24 Hours		
15	HUMIDITY TEST	After test meet Item 7 and 8	40 ± 2° C 90-95 % R.H. 24 Hours		

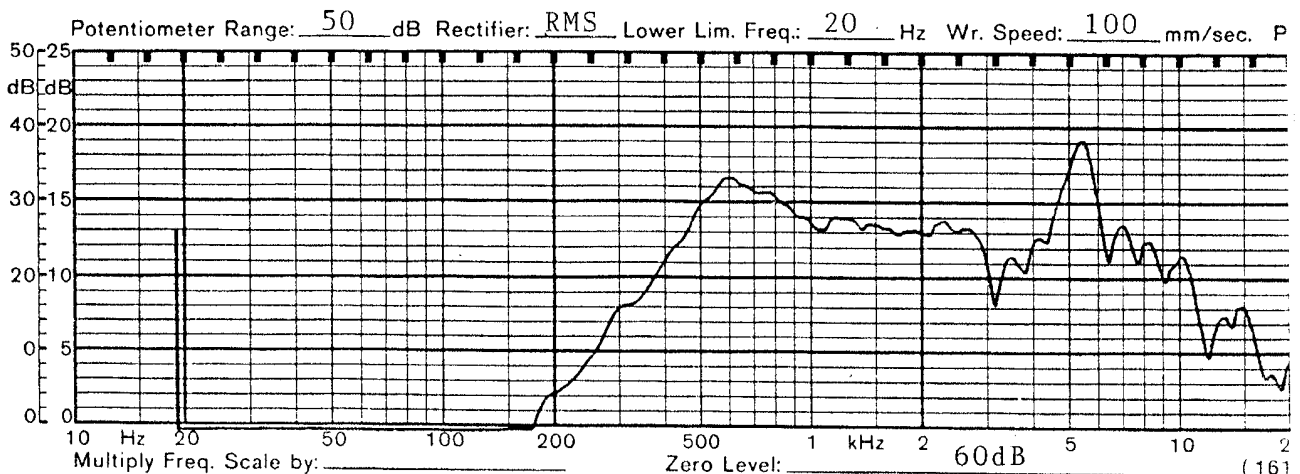

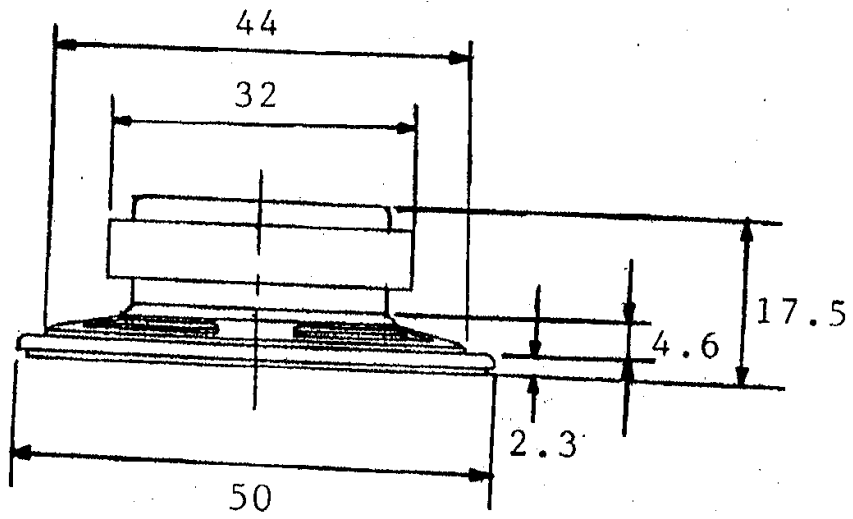
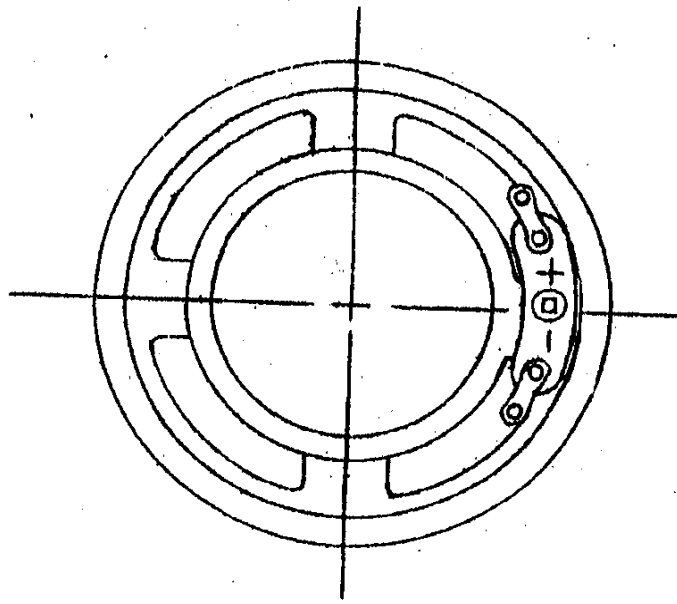

TOLERANCE: ± 0.8 MM

MODEL NO.		GF0501MHX
APPROVED	CHECKED	DRAWING