

SHOGYO INTERNATIONAL CORP.

www.shogyo.com

SPEAKER SPECIFICATIONS

MODEL NO.	GF0573B-1X (RoHS)				
1	NOMINAL SIZE	57 mm	2-1/4	inch	
2	IMPEDANCE	8 Ω ± 15%	at. 1K Hz	1 V	
3	RESONANCE FO	460 Hz ± 92 Hz	FO Hz	1 V	
4	S.P. LEVEL	91 dB/w ± 3 dB	1 W 50 cm average at		
5	FREQ. RESPONSE	Fo Hz ~ 20K Hz	MAX 10 dB	600, 800, 1K, 1.2K Hz	
6	INPUT POWER	Nominal Input 3 W	Handling Capacity 5 W		
7	OPERATION	Must be normal at program source 3 W			
8	BUZZ, RATTLE, ETC.	Must be normal at Sine Wave 4.89 V			
9	MAGNET	45 x 22 x 8 mm			
10	FLUX DENSITY	Gauss ± 10%	total flux max well within		
11	TOTAL WEIGHT		gr	oz	
12	LOAD TEST	After test meets Item 7 and 8	White noise 3 W 24 Hours		
13	DISTORTION				
14	HEAT TEST	After test meets Item 7 and 8	60 ± 2° C 20-50 % R.H. 24 Hours		
15	HUMIDITY TEST	After test meet Item 7 and 8	40 ± 2° C 90-95 % R.H. 24 Hours		

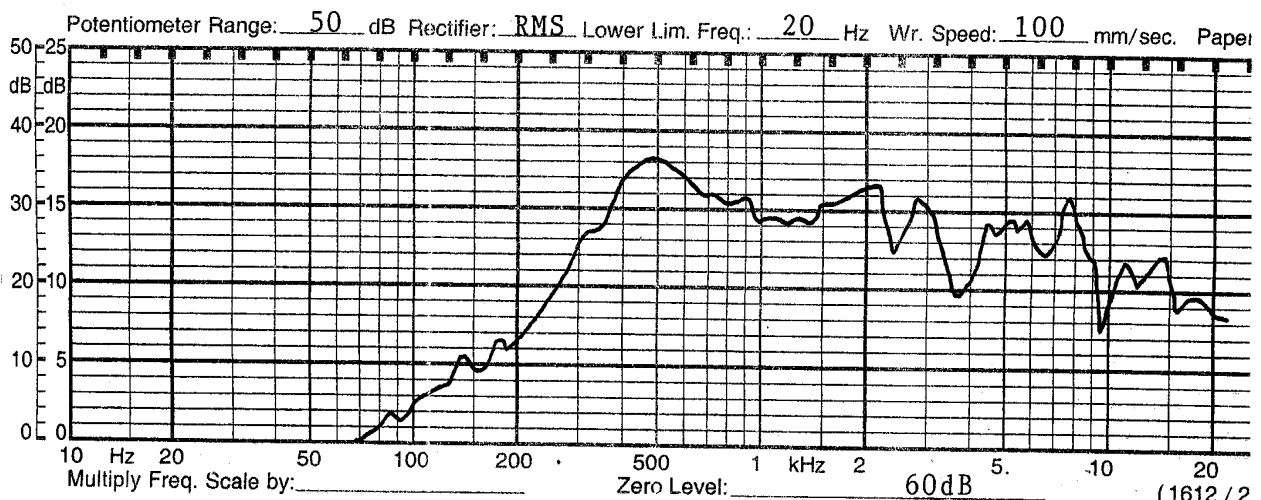

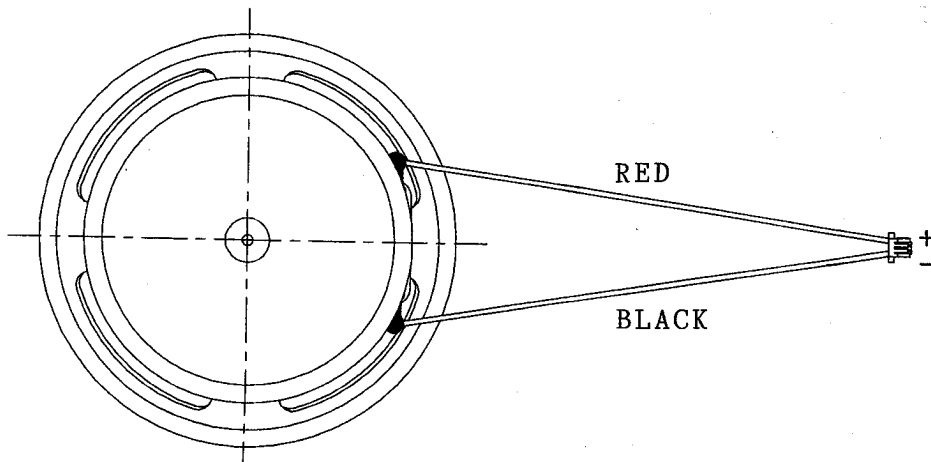

WIRE: UL1571 #26AWG
 LENGTH: 152±10 M/M
 CONNECTOR: JST ZHR-2

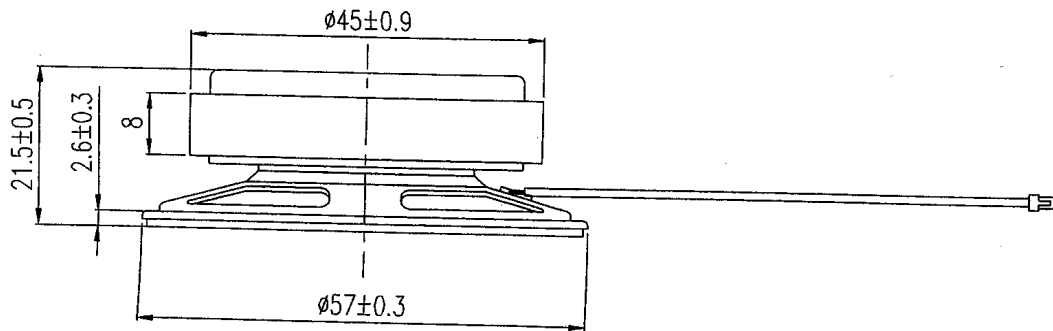

MODEL NO.		GF0573B-1X
APPROVED	CHECKED	DRAWING