

SHOGYO INTERNATIONAL CORP.

www.shogyo.com

SPEAKER SPECIFICATIONS

MODEL NO.	GF1202-1X (RoHS)				
1	NOMINAL SIZE	120 mm	5	inch	
2	IMPEDANCE	45 Ω ± 15%	at. 800 Hz	1 V	
3	RESONANCE FO	180 Hz ± 36 Hz	FO Hz	1 V	
4	S.P. LEVEL	95 dB/w ± 3 dB	1 W 50 cm average at		
5	FREQ. RESPONSE	Fo Hz ~ 14K Hz	MAX 10 dB	700, 900, 1K, 1.4K Hz	
6	INPUT POWER	Nominal Input 5 W	Handling Capacity 8 W		
7	OPERATION	Must be normal at program source 5 W			
8	BUZZ, RATTLE, ETC.	Must be normal at Sine Wave 15 V			
9	MAGNET	60 x 32 x 8 mm			
10	FLUX DENSITY	Gauss ± 10%	total flux max well within		
11	TOTAL WEIGHT	gr	oz		
12	LOAD TEST	After test meets Item 7 and 8	White noise 5 W 48 Hours		
13	DISTORTION				
14	HEAT TEST	After test meets Item 7 and 8	70 ± 2° C 20-50 % R.H. 48 Hours		
15	HUMIDITY TEST	After test meet Item 7 and 8	40 ± 2° C 90-95 % R.H. 48 Hours		

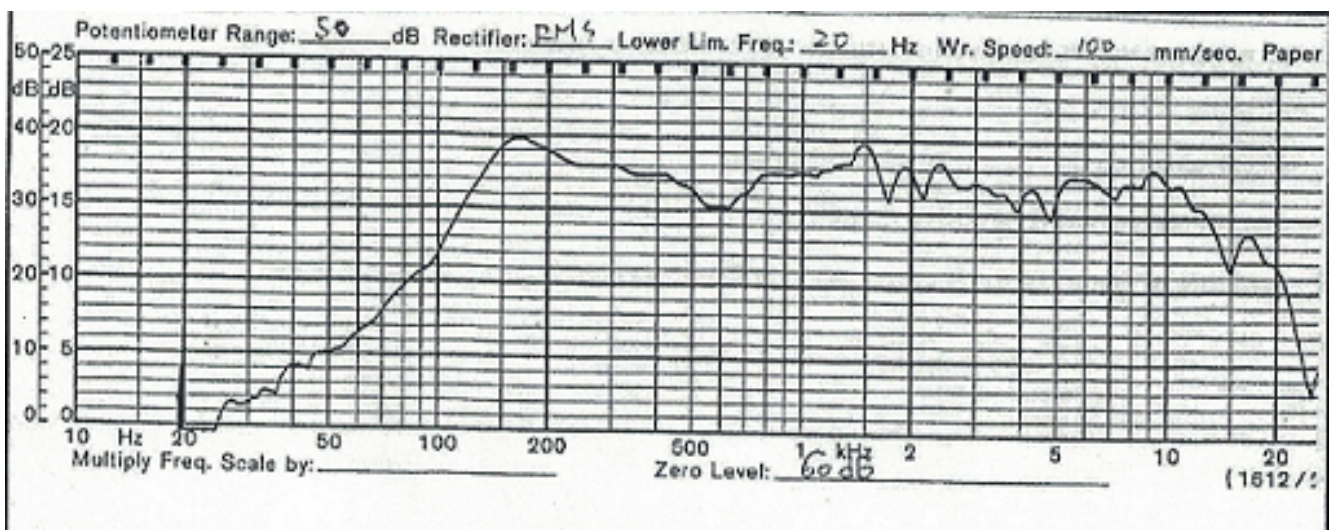

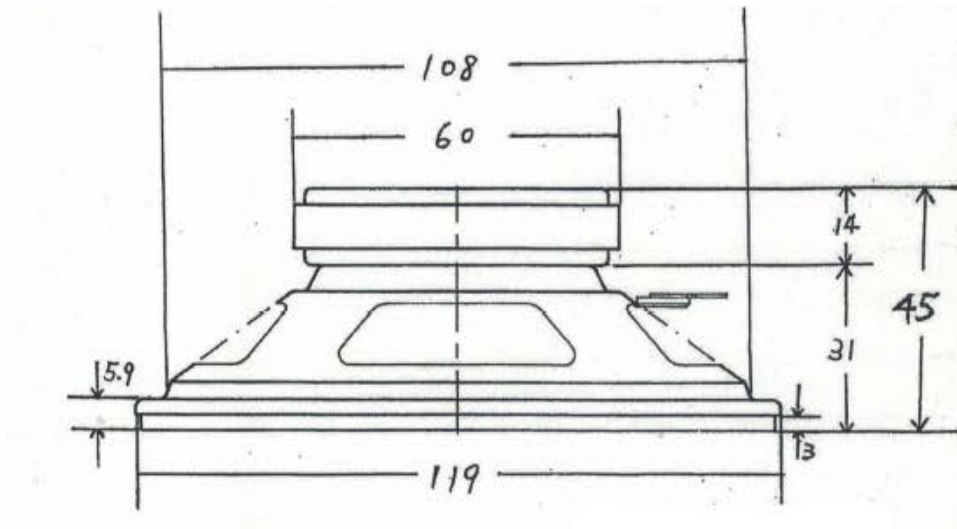
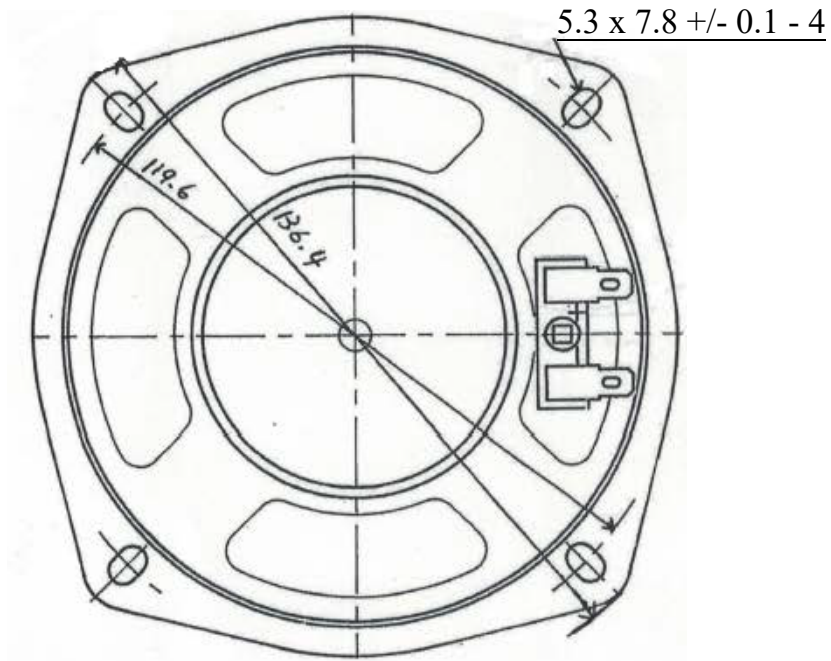

TOLERANCE: ± 0.7 MM

MODEL NO.		GF1202-1X
APPROVED	CHECKED	DRAWING