

# SHOGYO INTERNATIONAL CORP.

www.shogyo.com

## SPEAKER SPECIFICATIONS

<b>MODEL NO.</b>	<b>GF1258X (RoHS)</b>				
<b>1</b>	<b>NOMINAL SIZE</b>	<b>58 x 126.6 mm</b>	<b>2" x 5"</b>		
<b>2</b>	<b>IMPEDANCE</b>	<b>8 Ω ± 15%</b>	<b>at. 1K Hz</b>	<b>1 V</b>	
<b>3</b>	<b>RESONANCE FO</b>	<b>160 Hz ± 32 Hz</b>	<b>FO Hz</b>	<b>1 V</b>	
<b>4</b>	<b>S.P. LEVEL</b>	<b>90 dB/w ± 3 dB</b>	<b>1 W 50 cm average at</b>		
<b>5</b>	<b>FREQ. RESPONSE</b>	<b>Fo Hz ~ 20K Hz</b>			
<b>6</b>	<b>INPUT POWER</b>	Nominal Input <b>6 W</b>	Handling Capacity <b>10 W</b>		
<b>7</b>	<b>OPERATION</b>	Must be normal at program source <b>6 W</b>			
<b>8</b>	<b>BUZZ, RATTLE, ETC.</b>	Must be normal at Sine Wave <b>6.93 V</b>			
<b>9</b>	<b>MAGNET</b>	<b>60 x 32 x 8 mm</b>			
<b>10</b>	<b>FLUX DENSITY</b>	<b>Gauss ± 10%</b>	<b>total flux max well within</b>		
<b>11</b>	<b>TOTAL WEIGHT</b>	gr	oz		
<b>12</b>	<b>LOAD TEST</b>	After test meets Item 7 and 8	White noise <b>6 W 24 Hours</b>		
<b>13</b>	<b>DISTORTION</b>				
<b>14</b>	<b>HEAT TEST</b>	After test meets Item 7 and 8	<b>60 ± 2° C 20-50 % R.H. 24 Hours</b>		
<b>15</b>	<b>HUMIDITY TEST</b>	After test meet Item 7 and 8	<b>40 ± 2° C 90-95 % R.H. 24 Hours</b>		

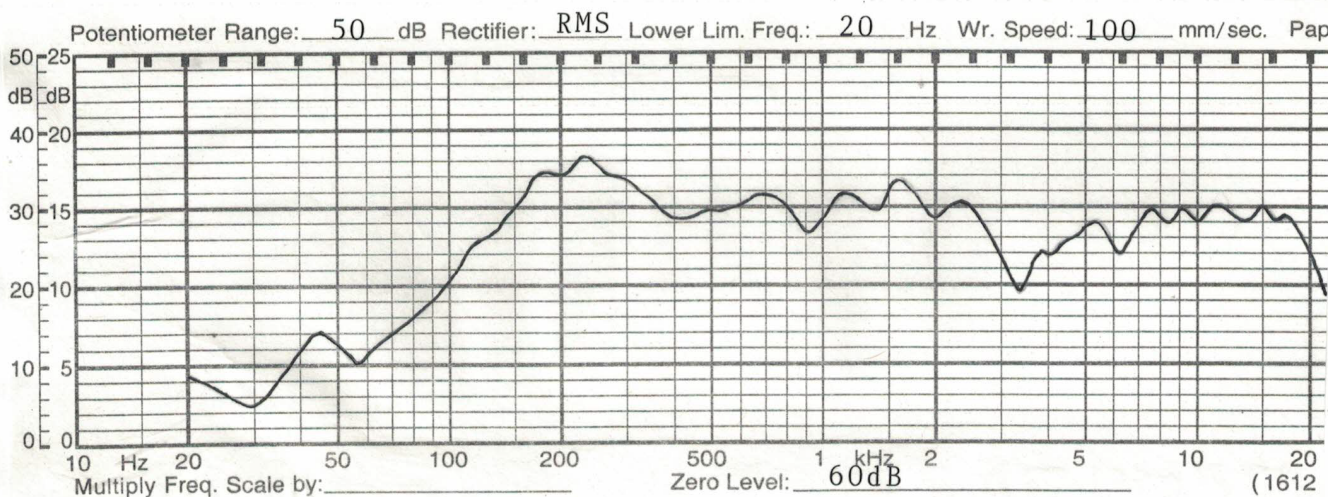

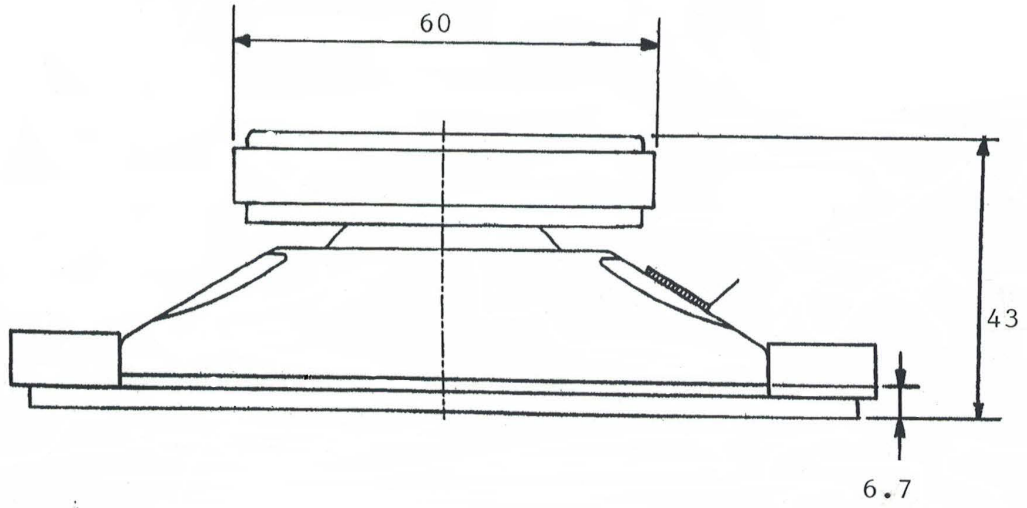
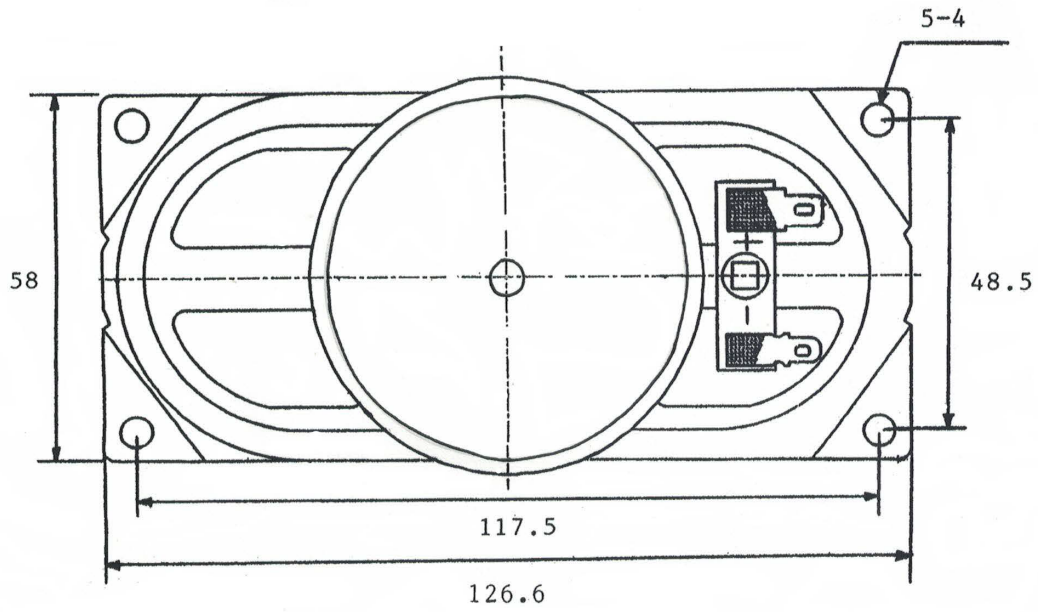

**TOLERANCE: ± 0.8 MM**

<b>MODEL NO.</b>		GF1258X
APPROVED	CHECKED	DRAWING