

SHOGYO INTERNATIONAL CORP.

www.shogyo.com

SPEAKER SPECIFICATIONS

MODEL NO.	GA0729X (RoHS)				
1	NOMINAL SIZE	48 x 72 mm	inch		
2	IMPEDANCE	8 Ω ± 15%	at. 800 Hz	1 V	
3	RESONANCE FO	400 Hz ± 80 Hz	FO Hz	1 V	
4	S.P. LEVEL	87 dB/w ± 3 dB	1 W 50 cm average at		
5	FREQ. RESPONSE	Fo Hz ~ 7K Hz	MAX 10 dB	1K, 1.4K, 1.7K, 2K Hz	
6	INPUT POWER	Nominal Input 1 W	Handling Capacity 2 W		
7	OPERATION	Must be normal at program source 1 W			
8	BUZZ, RATTLE, ETC.	Must be normal at Sine Wave 2.83 V			
9	MAGNET	13 x 10 mm			
10	FLUX DENSITY	Gauss ± 10%	total flux max well within		
11	TOTAL WEIGHT	gr	oz		
12	LOAD TEST	After test meets Item 7 and 8	White noise	1W 24 Hours	
13	DISTORTION				
14	HEAT TEST	After test meets Item 7 and 8	60 ± 2° C	20-50 % R.H.	24 Hours
15	HUMIDITY TEST	After test meet Item 7 and 8	40 ± 2° C	90-95 % R.H.	24 Hours

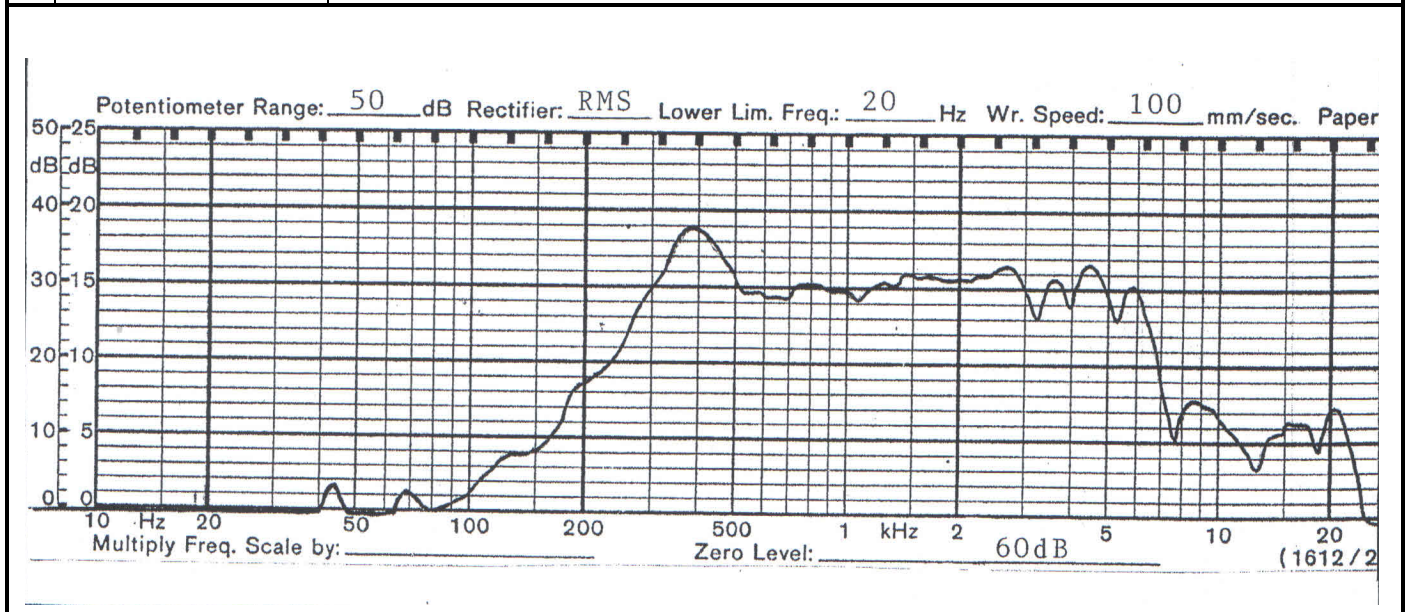

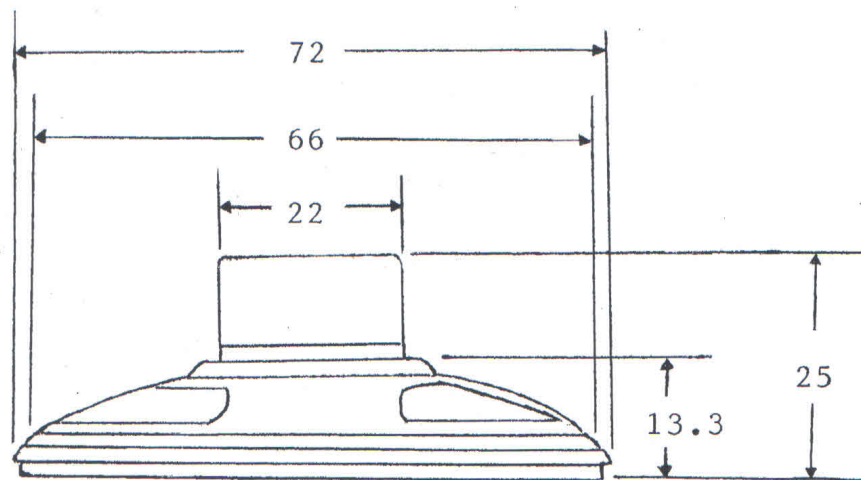
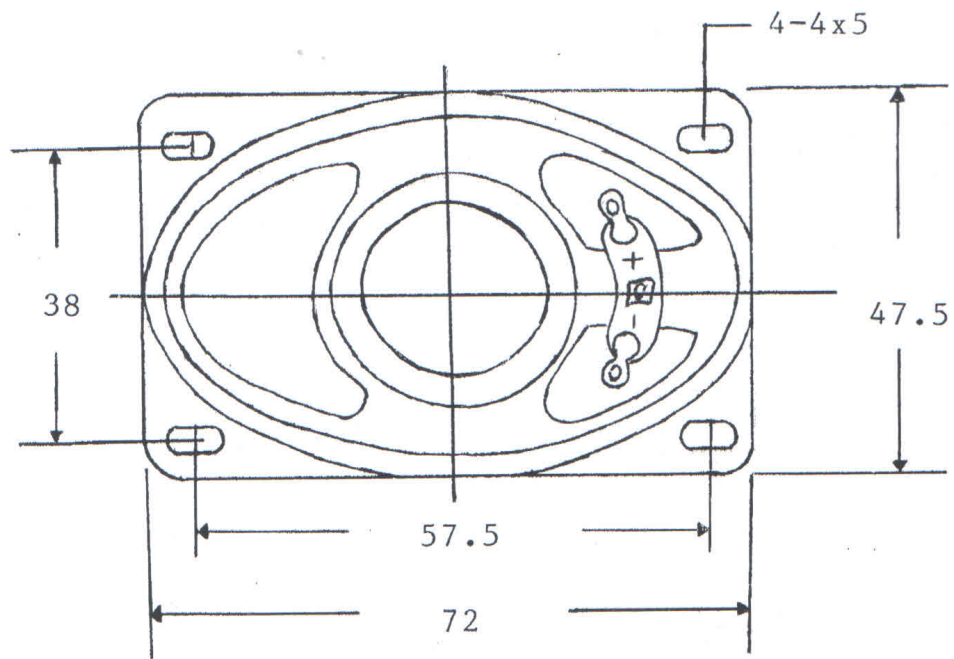

TOLERANCE: ± 0.8 MM

MODEL NO.

GA0729X

APPROVED

CHECKED

DRAWING