

# SHOGYO INTERNATIONAL CORP.

www.shogyo.com

## SPEAKER SPECIFICATIONS

MODEL NO.	<b>GA1009X (RoHS)</b>				
<b>1</b>	NOMINAL SIZE	<b>68 x 106 mm</b>	<b>2-1/2</b>	<b>inch</b>	
<b>2</b>	IMPEDANCE	<b>8 Ω ± 15%</b>	<b>at. 800 Hz</b>	<b>1 V</b>	
<b>3</b>	RESONANCE FO	<b>250 Hz ± 50 Hz</b>	<b>FO Hz</b>	<b>1 V</b>	
<b>4</b>	S.P. LEVEL	<b>90 dB/w ± 3 dB</b>	<b>1 W 50 cm average at</b>		
<b>5</b>	FREQ. RESPONSE	<b>Fo Hz ~ 15K Hz</b>			
<b>6</b>	INPUT POWER	Nominal Input <b>1 W</b>	Handling Capacity <b>2 W</b>		
<b>7</b>	OPERATION	Must be normal at program source <b>1 W</b>			
<b>8</b>	BUZZ, RATTLE, ETC.	Must be normal at Sine Wave <b>2.83 V</b>			
<b>9</b>	MAGNET	<b>13 x 10 mm</b>			
<b>10</b>	FLUX DENSITY	<b>Gauss ± 10%</b>	<b>total flux max well within</b>		
<b>11</b>	TOTAL WEIGHT		<b>gr</b>	<b>oz</b>	
<b>12</b>	LOAD TEST	After test meets Item 7 and 8	<b>White noise 1 W 24 Hours</b>		
<b>13</b>	DISTORTION				
<b>14</b>	HEAT TEST	After test meets Item 7 and 8	<b>60 ± 2° C 20-50 % R.H. 24 Hours</b>		
<b>15</b>	HUMIDITY TEST	After test meet Item 7 and 8	<b>40 ± 2° C 90-95 % R.H. 24 Hours</b>		

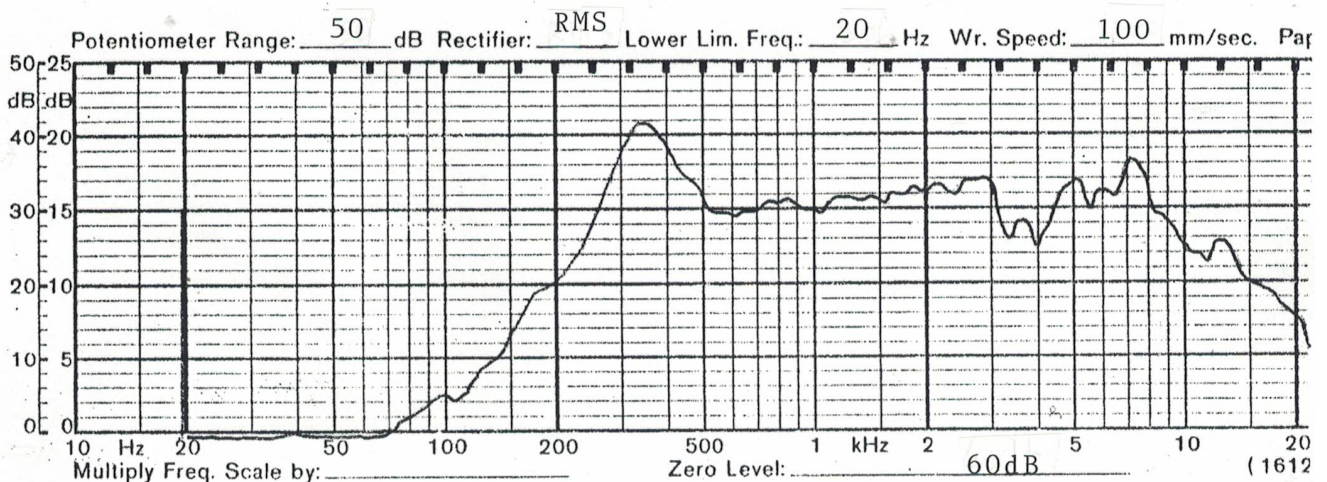

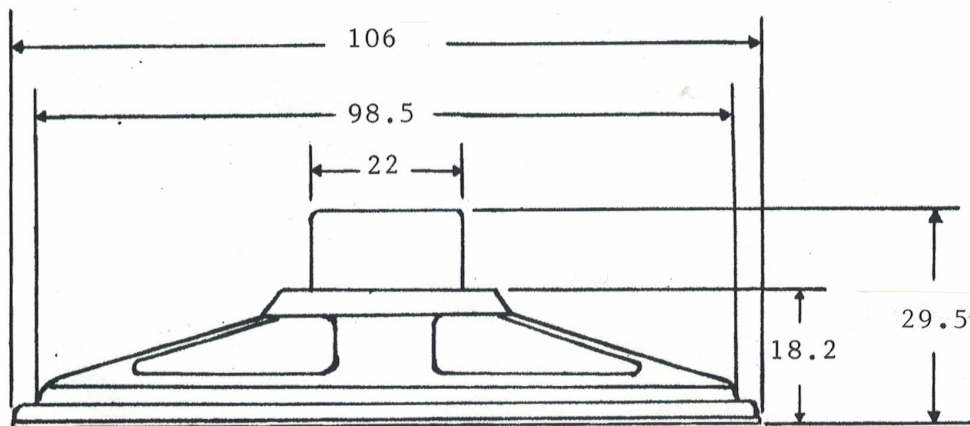
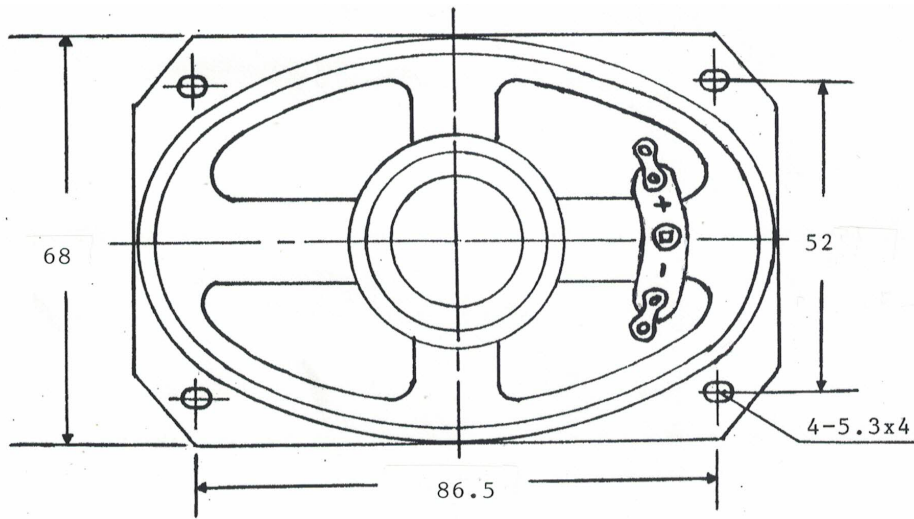

**TOLERANCE: ± 0.8 MM**

<b>MODEL NO.</b>		
GA1009X		
APPROVED	CHECKED	DRAWING